



車頭碗組

HEADSETS

H02



WEIGHT 50g
SIZE 1" Integrated Threadless Headset
SHIS NORM IS38.2/25.4 | IS38.2/27(26.4)

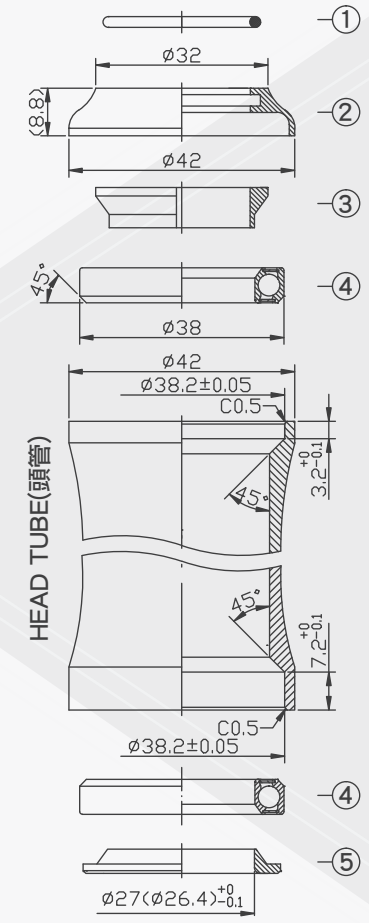

堆積高度(STACK HEIGHT)=10.5±1mm

NO.	零件名稱 PART NAME	材質 MATERIAL	圖號 DRAWING NO.	台量 Q'TY	尺寸 DIM. DESCRIPTION
1	O形圈 O-Ring	橡膠 NBR	121-8	1	ID25.3xØ2
2	鋁上塞 TOP COVER	鋁合金 6061/T6	02-3	1	1"
3	鋁斜管 COMPRESSION RING	鋁合金 6061/T6	2019	1	1"
4	密封式軸承 A.C. SEALED BEARING	軸承鋼 SUJ2	NHB-3A	2	OD38 x 36° x45°
5	鋁下塞 CROWN RACE	鋁合金 7075/T6	02-6	1	Ø27(Ø26.4)

H22



WEIGHT 55g
SIZE 1-1/8" Integrated Threadless Headset
SHIS NORM IS41.2/28.6 | IS41.2/30

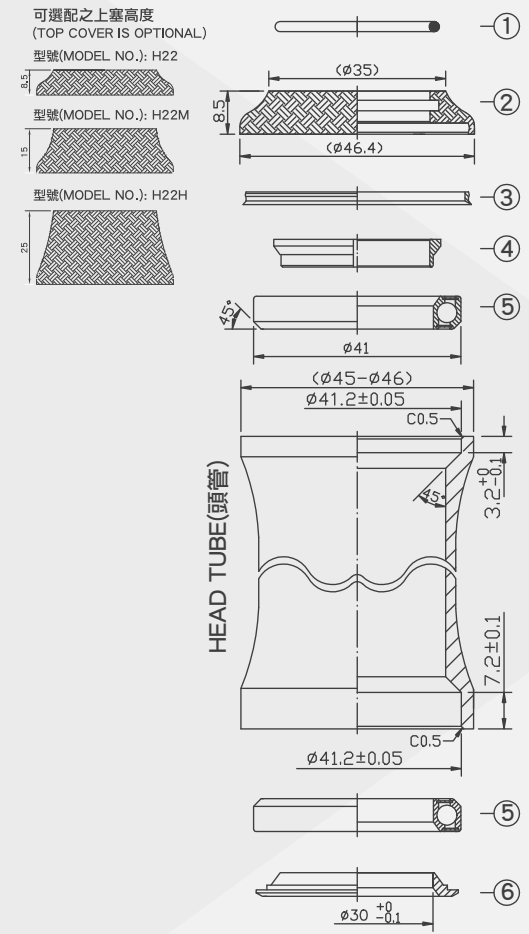

堆積高度(STACK HEIGHT)=10.2±1mm

NO.	零件名稱 PART NAME	材質 MATERIAL	圖號 DRAWING NO.	台量 Q'TY	尺寸 DIM. DESCRIPTION
1	O形圈 O-Ring	橡膠 NBR	120-8	1	ID28.5xØ2
2	碳纖維上塞 TOP COVER	碳纖維 CARBON FIBER	22-3	1	1-1/8"
3	防塵蓋 UPPER WATER SEAL	橡膠 NBR	51-0	1	
4	鋁斜管 COMPRESSION RING	鋁合金 6061/T6	773-2	1	1-1/8"
5	密封式軸承 A.C. SEALED BEARING	軸承鋼 SUJ2	NHB-5D	2	OD41x36° x45°
6	鋁下塞 CROWN RACE	鋁合金 7075/T6	123-6	1	Ø30 ⁺⁰ _{-0.1}

H23



WEIGHT 60.3g
SIZE 1-1/8" Integrated Threadless Headset
SHIS NORM IS41.2/28.6 | IS41.2/30

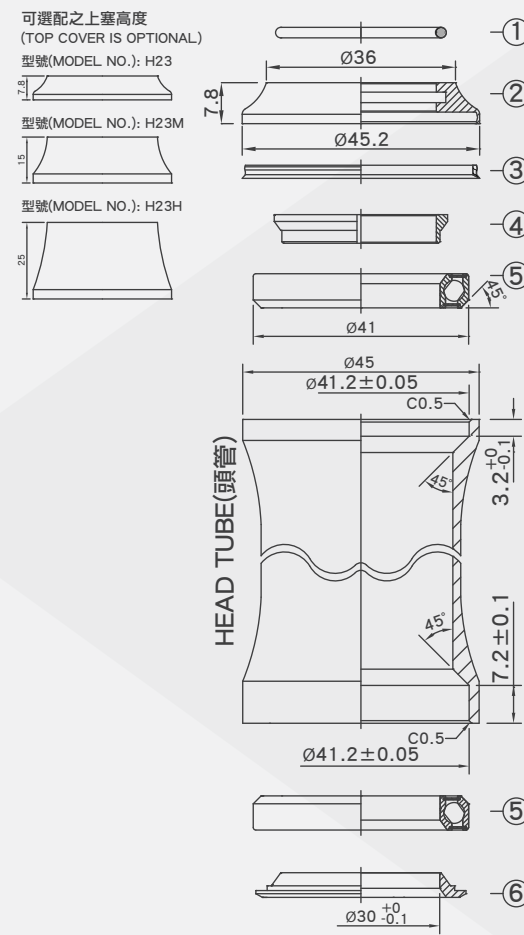

堆積高度(STACK HEIGHT)=9.5±1mm

NO.	零件名稱 PART NAME	材質 MATERIAL	圖號 DRAWING NO.	台量 Q' TY	尺寸 DIM. DESCRIPTION
1	O形圈 O-Ring	橡膠 NBR	120-8	1	ID28.5xØ2
2	鋁上塞 TOP COVER	鋁合金 6061/T6	23-3	1	1-1/8"
3	防塵蓋 UPPER WATER SEAL	橡膠 NBR	51-0	1	
4	鋁斜管 COMPRESSION RING	鋁合金 6061/T6	773-2	1	1-1/8"
5	密封式軸承 A.C. SEALED BEARING	軸承鋼 SUJ2	NHB-5D	2	OD41x36"x45"
6	鋁下塞 CROWN RACE	鋁合金 7075/T6	123-6	1	Ø30 ⁺⁰ _{-0.1}

H27



WEIGHT 61g
SIZE 1-1/8" Integrated Threadless Headset
Campy Compatible
SHIS NORM IS42/28.6 | IS42/30

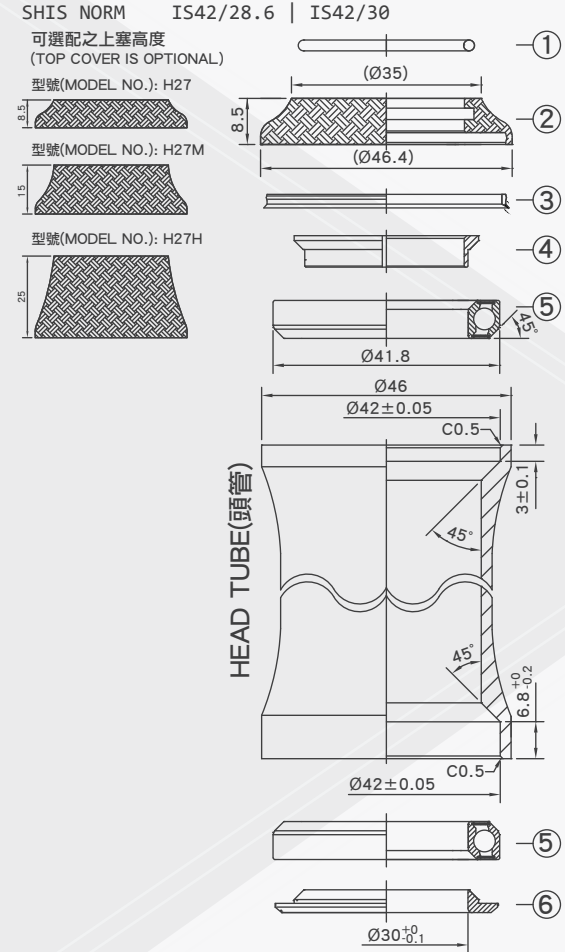

堆積高度(STACK HEIGHT)=10.1±1mm

NO.	零件名稱 PART NAME	材質 MATERIAL	圖號 DRAWING NO.	台量 Q' TY	尺寸 DIM. DESCRIPTION
1	O形圈 O-Ring	橡膠 NBR	120-8	1	ID28.5xØ2
2	碳纖維上塞 TOP COVER	碳纖維 CARBON FIBER	22-3	1	1-1/8"
3	防塵蓋 UPPER WATER SEAL	橡膠 NBR	51-0	1	
4	鋁斜管 COMPRESSION RING	鋁合金 6061/T6	51-2	1	1-1/8"
5	密封式軸承 A.C. SEALED BEARING	軸承鋼 SUJ2	NHB-6B	2	OD41.8 x 45" x 45"
6	鋁下塞 CROWN RACE	鋁合金 7075/T6	51-6	1	Ø30 ⁺⁰ _{-0.1}

H50



WEIGHT 64g
SIZE 1-1/8" Integrated Threadless Headset
SHIS NORM IS41.2/28.6 | IS41.2/30

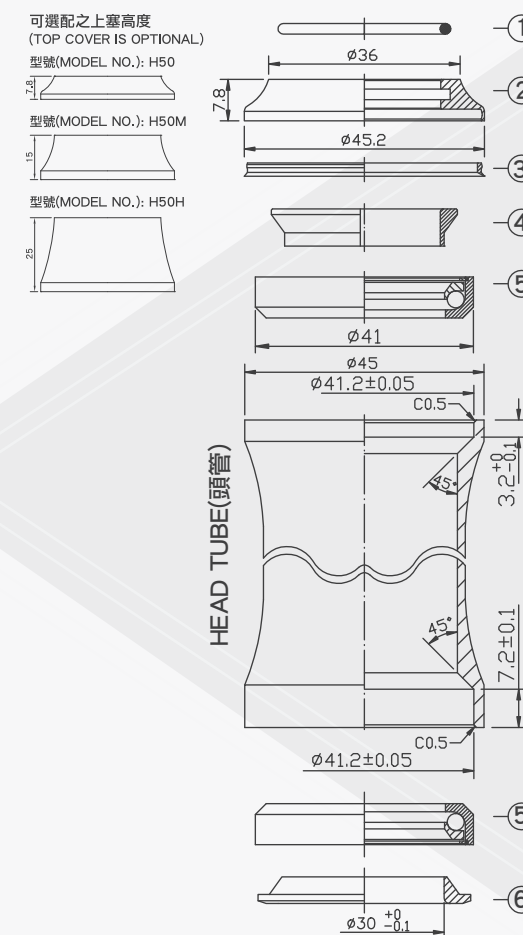

堆積高度(STACK HEIGHT)=9.8±1mm

NO.	零件名稱 PART NAME	材質 MATERIAL	圖號 DRAWING NO.	台量 Q' TY	尺寸 DIM. DESCRIPTION
1	O形圈 O-Ring	橡膠 NBR	120-8	1	ID28.5xØ2
2	鋁上塞 TOP COVER	鋁合金 6061/T6	23-3	1	1-1/8"
3	防塵蓋 UPPER WATER SEAL	橡膠 NBR	51-0	1	
4	塑膠斜管 COMPRESSION RING	塑膠 PLASTIC	2036	1	1-1/8"
5	卡式軸承 CARTRIDGE BALL BEARING	鋁鉻鋼 CR-MO STEEL	CBB-41	2	OD41 x 36" x 45"
6	下塞 CROWN RACE	碳鋼 STEEL	146-6	1	Ø30 ⁺⁰ _{-0.1}

H51



WEIGHT 65g
SIZE 1-1/8" Integrated Threadless Headset
Campy Compatible
SHIS NORM IS42/28.6 | IS42/30

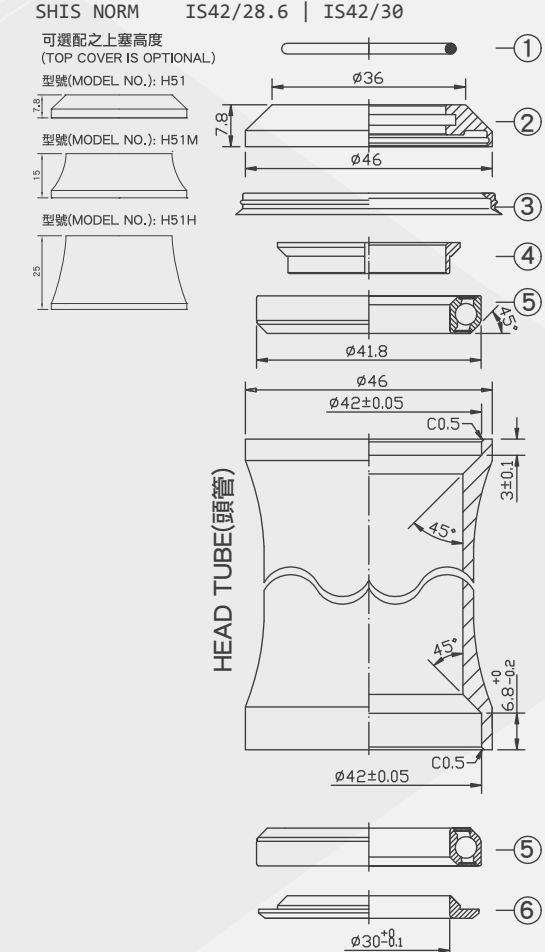

堆積高度(STACK HEIGHT)=9.4±1mm

NO.	零件名稱 PART NAME	材質 MATERIAL	圖號 DRAWING NO.	台量 Q' TY	尺寸 DIM. DESCRIPTION
1	O形圈 O-Ring	橡膠 NBR	120-8	1	ID28.5xØ2
2	鋁上塞 TOP COVER	鋁合金 6061/T6	51-3	1	1-1/8"
3	防塵蓋 UPPER WATER SEAL	橡膠 NBR	273-0	1	
4	鋁斜管 COMPRESSION RING	鋁合金 6061/T6	51-2	1	1-1/8"
5	密封式軸承 A.C. SEALED BEARING	軸承鋼 SUJ2	NHB-6B	2	OD41.8 x 45" x 45"
6	鋁下塞 CROWN RACE	鋁合金 6061/T6	51-6	1	Ø30 ⁺⁰ _{-0.1}

H51S



WEIGHT 70g
SIZE 1-1/8" Head Tube Reduced to 1" Fork Stem Integrated Threadless Headset

SHIS NORM IS42/25.4 | IS42/27(26.4)

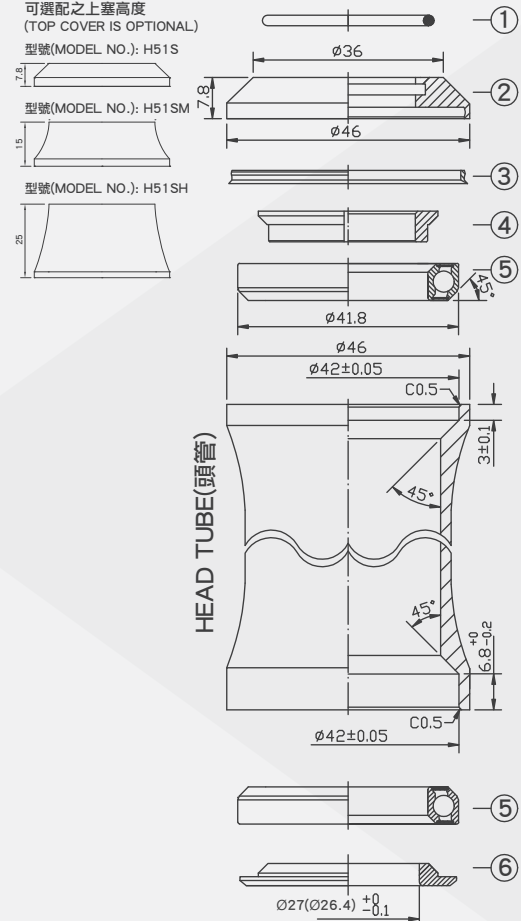

堆積高度(STACK HEIGHT)=9.4±1mm

NO.	零件名稱 PART NAME	材質 MATERIAL	圖號 DRAWING NO.	台量 Q' TY	尺寸 DIM. DESCRIPTION
1	O形圈 O-Ring	橡膠 NBR	121-8	1	ID25.3xØ2
2	鋁上塞 TOP COVER	鋁合金 6061/T6	05-3	1	1"
3	防塵蓋 UPPER WATER SEAL	橡膠 NBR	273-0	1	
4	鋁斜管 COMPRESSION RING	鋁合金 6061/T6	05-2	1	1"
5	密封式軸承 A.C. SEALED BEARING	軸承鋼 SUJ2	NHB-6B	2	OD41.8x45°x45°
6	鋁下塞 CROWN RACE	鋁合金 7075/T6	05-6	1	Ø27(Ø26.4) ⁺⁰ _{-0.1}

H52



WEIGHT 74g
SIZE 1-1/8" Integrated Threadless Headset Campy Compatible

SHIS NORM IS42/28.6 | IS42/30

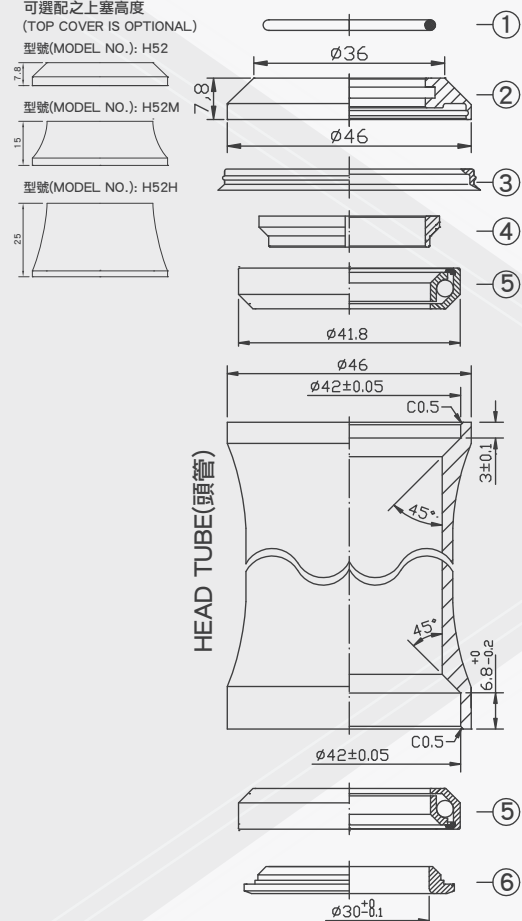

堆積高度(STACK HEIGHT)=9.4±1mm

NO.	零件名稱 PART NAME	材質 MATERIAL	圖號 DRAWING NO.	台量 Q' TY	尺寸 DIM. DESCRIPTION
1	O形圈 O-Ring	橡膠 NBR	120-8	1	ID28.5xØ2
2	鋁上塞 TOP COVER	鋁合金 6061/T6	51-3	1	1-1/8"
3	防塵蓋 UPPER WATER SEAL	橡膠 NBR	273-0	1	
4	鋁斜管 COMPRESSION RING	鋁合金 6061/T6	52-2	1	1-1/8"
5	卡式軸承 CARTRIDGE BALL BEARING	鉻鉬鋼 CR-MO STEEL	CBB-418	2	OD41.8x45°x45°
6	下塞 CROWN RACE	碳鋼 STEEL	52-6	1	Ø30 ⁺⁰ _{-0.1}

H52MP

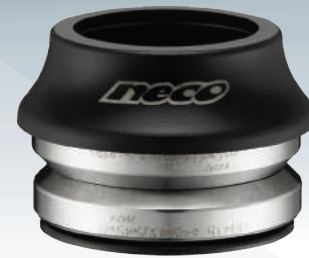

WEIGHT 70g
SIZE 1-1/8" Integrated Threadless Headset Campy Compatible

SHIS NORM IS42/28.6 | IS42/30

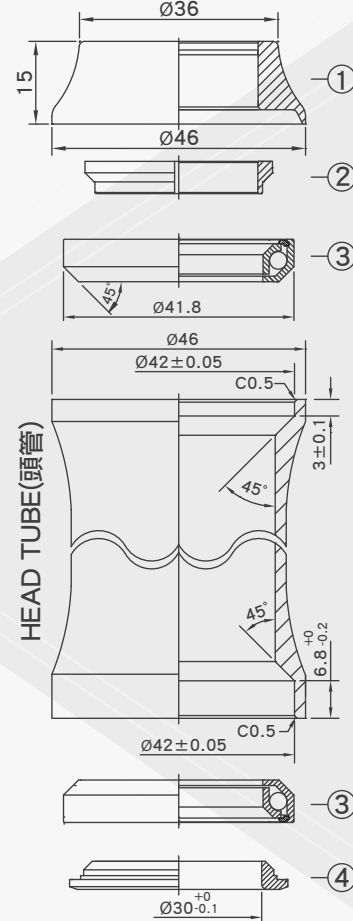

堆積高度(STACK HEIGHT)=16.2±1mm

NO.	零件名稱 PART NAME	材質 MATERIAL	圖號 DRAWING NO.	台量 Q' TY	尺寸 DIM. DESCRIPTION
1	塑鋼上蓋 TOP COVER	塑鋼 PC	51MP-3	1	1-1/8"
2	鋁斜管 COMPRESSION RING	鋁合金 6061/T6	52-2	1	1-1/8"
3	卡式軸承 CARTRIDGE BALL BEARING	鉻鉬鋼 CR-MO STEEL	CBB-418	2	OD41.8x45°x45°
4	下塞 CROWN RACE	碳鋼 STEEL	52-6	1	Ø30 ⁺⁰ _{-0.1}

H160



WEIGHT 85g
SIZE 1.5" Head Tube Reduced to 1-1/4" Fork Tube Integrated Threadless Headset

SHIS NORM IS47/31.8 | IS52/39.8(33)

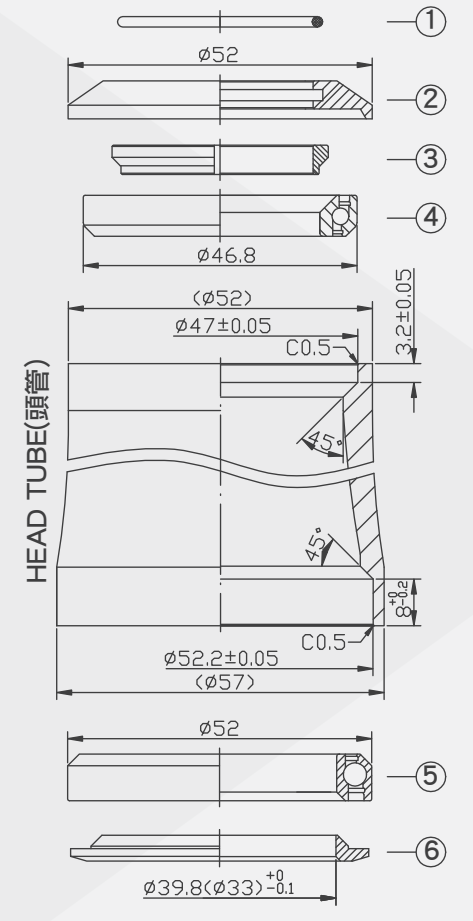

堆積高度(STACK HEIGHT)=8.2±1mm

NO.	零件名稱 PART NAME	材質 MATERIAL	圖號 DRAWING NO.	台量 Q' TY	尺寸 DIM. DESCRIPTION
1	O形圈 O-Ring	橡膠 NBR	160-8	1	ID31.5xØ1.78
2	上塞 TOP COVER	鋁合金 6061/T6	160-3	1	1-1/4"
3	鋁斜管 COMPRESSION RING	鋁合金 6061/T6	160-2	1	1-1/4"
4	密封式軸承 A.C. SEALED BEARING	軸承鋼 SUJ2	ACB-468	1	OD46.8x45°x45°
5	特大型密封式軸承 OVERSIZE A.C. SEALED BEARING	軸承鋼 SUJ2	NHB-15	1	OD52x45°x45°
6	鋁下塞 CROWN RACE	鋁合金 7075/T6	151-6	1	Ø39.8(Ø33) ⁺⁰ _{-0.1}

H373 [H373C]



WEIGHT 80g
SIZE 1.5" Head Tube Reduced to 1-1/8" Fork Tube Integrated Threadless Headset
SHIS NORM IS42/28.6 | IS52.2/39.8(30)
OPTIONAL H373C-Carbon Top Cover Height 10.4 ± 1mm

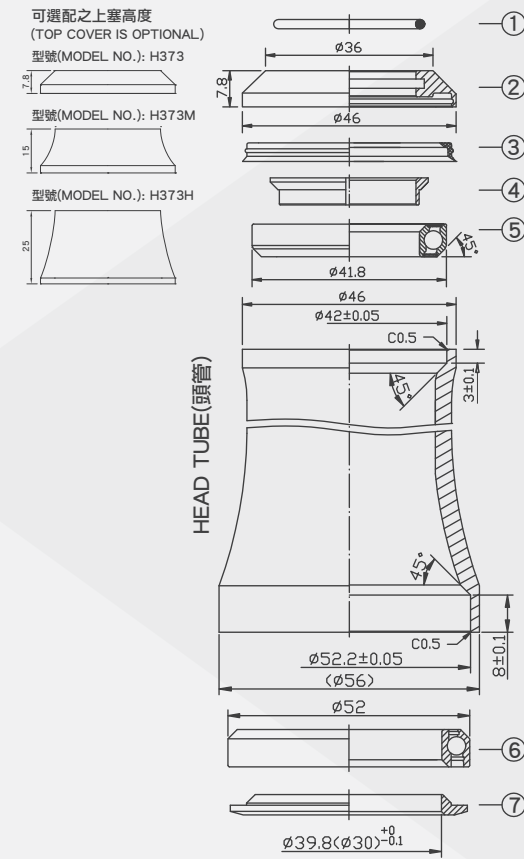

堆積高度(STACK HEIGHT)= 9.7 ± 1mm

NO.	零件名稱 PART NAME	材質 MATERIAL	圖號 DRAWING NO.	台量 Q' TY	尺寸 DIM. DESCRIPTION
1	O形圈 O-Ring	橡膠 NBR	120-8	1	ID28.5xØ2
2	上塞 TOP COVER	鋁合金 6061/T6	51-3	1	1-1/8"
3	防塵蓋 UPPER WATER SEAL	橡膠 NBR	273-0	1	
4	鋁斜管 COMPRESSION RING	鋁合金 6061/T6	51-2	1	1-1/8"
5	密封式軸承 A.C. SEALED BEARING	軸承鋼 SUJ2	NHB-6B	1	OD41.8 × 45° × 45°
6	特大型密封式軸承 OVERSIZE A.C. SEALED BEARING	軸承鋼 SUJ2	NHB-15	1	OD 52 × 45° × 45°
7	鋁下塞 CROWN RACE	鋁合金 7075/T6	151-6(153-6)	1	Ø39.8(Ø30) ^{+0.1} _{-0.1}

H373S



WEIGHT 83.6g
SIZE 1.5" Head Tube Reduced to 1-1/8" Fork Tube Integrated Threadless Headset
SHIS NORM IS42/28.6 | IS52.2/39.8(30)

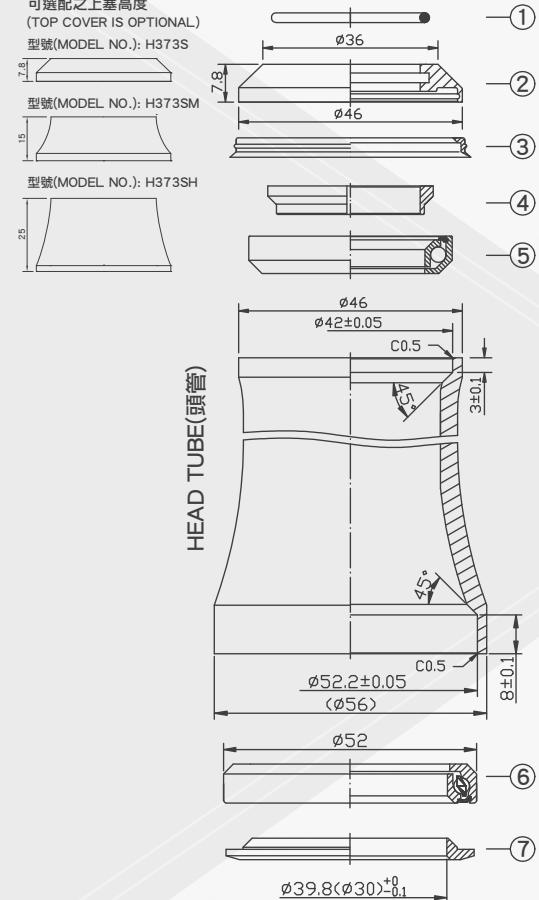

堆積高度(STACK HEIGHT)= 9.4 ± 1mm

NO.	零件名稱 PART NAME	材質 MATERIAL	圖號 DRAWING NO.	台量 Q' TY	尺寸 DIM. DESCRIPTION
1	O形圈 O-Ring	橡膠 NBR	120-8	1	ID28.5xØ2
2	上塞 TOP COVER	鋁合金 6061/T6	51-3	1	1-1/8"
3	防塵蓋 UPPER WATER SEAL	橡膠 NBR	273-0	1	
4	鋁斜管 COMPRESSION RING	鋁合金 6061/T6	52-2	1	1-1/8"
5	卡式軸承 CARTRIDGE BALL BEARING	鉻鉬鋼 CR-MO STEEL	CBB-418	1	OD41.8 × 45° × 45°
6	特大卡式軸承 OVERSIZE CARTRIDGE BALL BEARING	鉻鉬鋼 CR-MO STEEL	CBB-52	1	OD52 × 45° × 45°
7	鋁下塞 CROWN RACE	鋁合金 7075/T6	151-6(153-6)	1	Ø39.8(Ø30) ^{+0.1} _{-0.1}

H373GMP

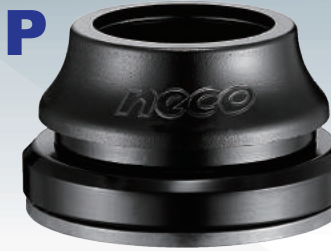

WEIGHT 88g
SIZE 1.5" Head Tube Reduced to 1-1/8" Fork Tube Integrated Threadless Headset
SHIS NORM IS42/28.6 | IS52.2/39.8 (30)

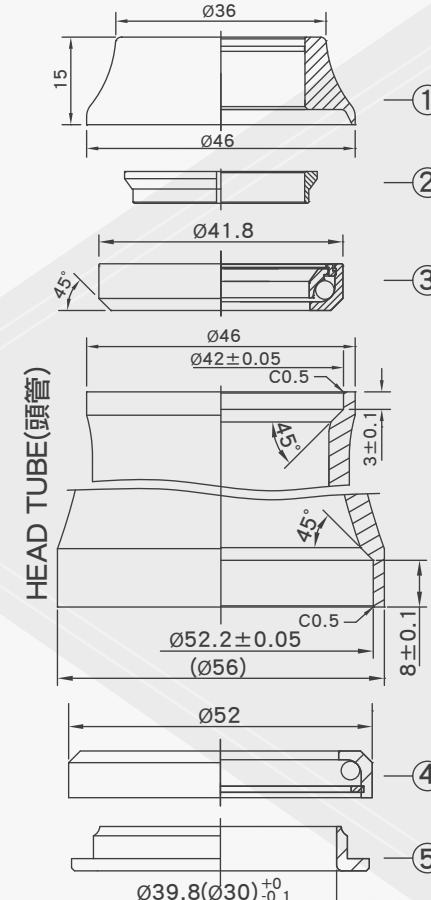

堆積高度(STACK HEIGHT)= 16.6 ± 1mm

NO.	零件名稱 PART NAME	材質 MATERIAL	圖號 DRAWING NO.	台量 Q' TY	尺寸 DIM. DESCRIPTION
1	上塞 TOP COVER	塑鋼 PC	51MP-3	1	1-1/8"
2	鋁斜管 COMPRESSION RING	鋁合金 6061/T6	773-2	1	1-1/8"
3	卡式上碗 UPPER CARTRIDGE STEEL CUP	碳鋼 STEEL	373G-4	1	Ø41.8
4	卡式下碗 LOWER CARTRIDGE STEEL CUP	碳鋼 STEEL	373G-5	1	Ø52
5	鐵下塞 CROWN RACE	碳鋼 STEEL	373G-6	1	Ø39.8(Ø30) ^{+0.1} _{-0.1}

H373MPS



WEIGHT 79.7g
SIZE 1.5" Head Tube Reduced to 1-1/8" Fork Tube Integrated Threadless Headset
SHIS NORM IS42/28.6 | IS52.2/39.8(30)

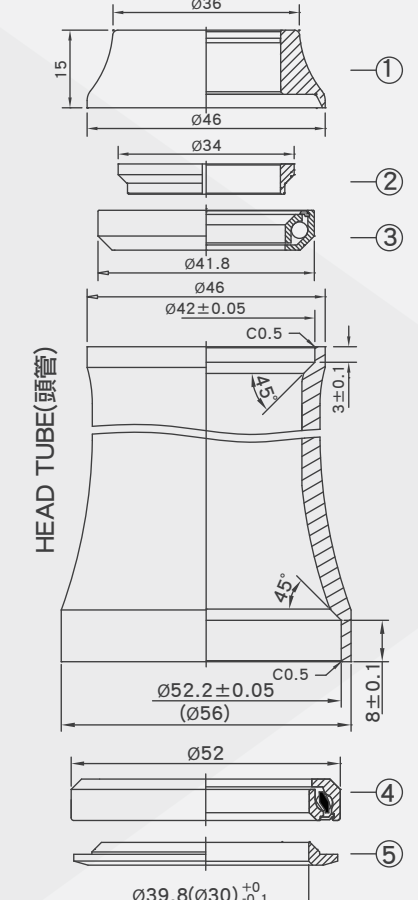

堆積高度(STACK HEIGHT)= 16.3 ± 1mm

NO.	零件名稱 PART NAME	材質 MATERIAL	圖號 DRAWING NO.	台量 Q' TY	尺寸 DIM. DESCRIPTION
1	上塞 TOP COVER	塑鋼 PC	51MP-3	1	1-1/8"
2	鋁斜管 COMPRESSION RING	鋁合金 6061/T6	52-2	1	1-1/8"
3	卡式軸承 CARTRIDGE BALL BEARING	鉻鉬鋼 CR-MO STEEL	CBB-418	1	OD41.8 × 45° × 45°
4	特大型卡式軸承 OVERSIZE CARTRIDGE BALL BEARING	鉻鉬鋼 CR-MO STEEL	CBB-52	1	OD52 × 45° × 45°
5	鋁下塞 CROWN RACE	鋁合金 7075/T6	151-6 (153-6)	1	Ø39.8(Ø30) ^{+0.1} _{-0.1}

H373-B52



WEIGHT 80g
SIZE 1-1/5" Head Tube Reduced to 1-1/8" Fork Tube Integrated Threadless Headset
SHIS NORM IS42/28.6 | IS52/39.8(30)

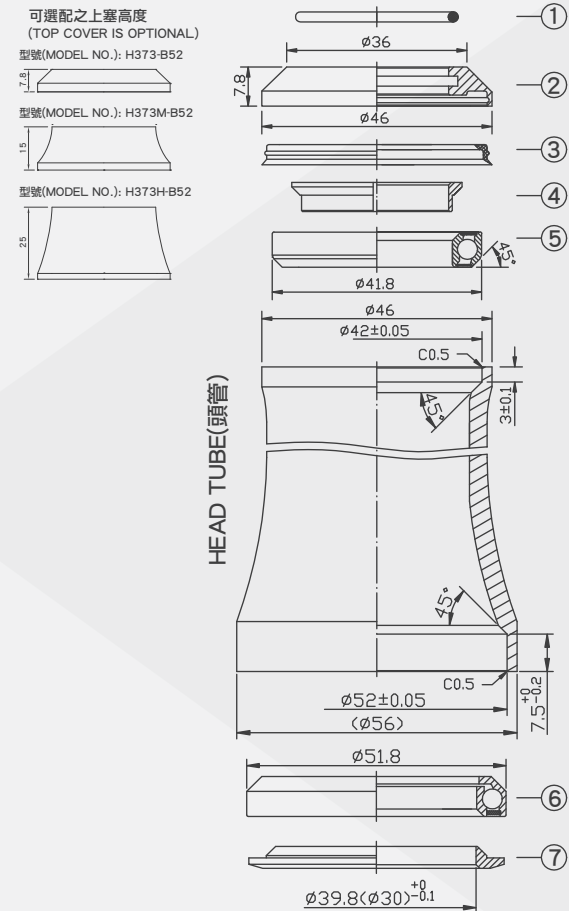

堆積高度(STACK HEIGHT)=9.5 ± 1mm

NO.	零件名稱 PART NAME	材質 MATERIAL	圖號 DRAWING NO.	台量 Q' TY	尺寸 DIM. DESCRIPTION
1	O形圈 O-Ring	橡膠 NBR	120-8	1	ID28.5xØ2
2	上塞 TOP COVER	鋁合金 6061/T6	51-3	1	1-1/8"
3	防塵蓋 UPPER WATER SEAL	橡膠 NBR	273-0	1	
4	鋁斜管 COMPRESSION RING	鋁合金 6061/T6	51-2	1	1-1/8"
5	密封式軸承 A.C. SEALED BEARING	軸承鋼 SUJ2	NHB-6B	1	OD41.8x45°x45°
6	特大卡式軸承 OVERSIZE CARTRIDGE BALL BEARING	軸承鋼 SUJ2	CBB-518	1	OD51.8x45°x45°
7	鋁下塞 CROWN RACE	鋁合金 7075/T6	151-6 (153-6)	1	Ø39.8(Ø30) ^{+0/-0.1}

H373G



WEIGHT 87g
SIZE 1.5" Head Tube Reduced to 1-1/8" Fork Tube Integrated Threadless Headset
SHIS NORM IS42/28.6 | IS52.2/39.8 (30)

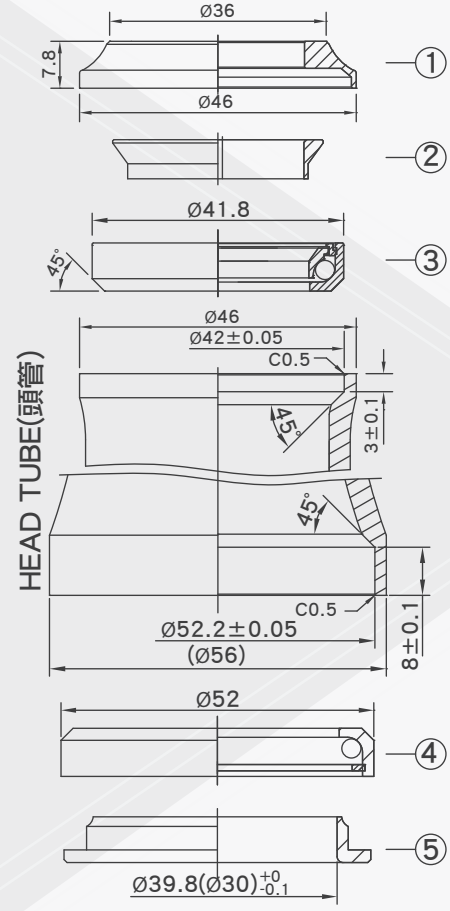

堆積高度(STACK HEIGHT)=9.1 ± 1mm

NO.	零件名稱 PART NAME	材質 MATERIAL	圖號 DRAWING NO.	台量 Q' TY	尺寸 DIM. DESCRIPTION
1	上塞 TOP COVER	鋁合金 6061/T6	373G-3	1	1-1/8"
2	塑膠斜管 COMPRESSION RING	塑膠 NBR	2036	1	1-1/8"
3	卡式上碗 UPPER CARTRIDGE STEEL CUP	碳鋼 STEEL	373G-4	1	Ø41.8
4	卡式下碗 LOWER CARTRIDGE STEEL CUP	碳鋼 STEEL	373G-5	1	Ø52
5	鐵下塞 CROWN RACE	碳鋼 STEEL	373G-6	1	Ø39.8(Ø30) ^{+0/-0.1}

H382 [1.5"]



WEIGHT 99g
SIZE 1.5" Integrated Threadless Headset
SHIS NORM IS52.2/38.1 | IS52.2/39.8

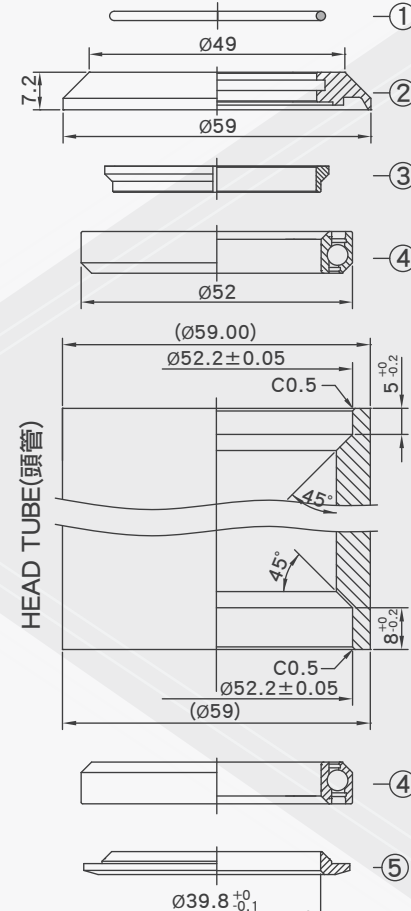

堆積高度(STACK HEIGHT)=9.1 ± 1mm

NO.	零件名稱 PART NAME	材質 MATERIAL	圖號 DRAWING NO.	台量 Q' TY	尺寸 DIM. DESCRIPTION
1	O形圈 O-Ring	橡膠 NBR	151-8	1	ID37.82xØ1.78
2	鋁上塞 TOP COVER	鋁合金 6061/T6	151-3	1	1.5"
3	鋁斜管 COMPRESSION RING	鋁合金 6061/T6	151-2	1	1.5"
4	特大型密封式軸承 OVERSIZE A.C. SEALED BEARING	軸承鋼 SUJ2	NHB-15	2	OD52x45°x45°
5	鋁下塞 CROWN RACE	鋁合金 7075/T6	151-6	1	Ø39.8 ^{+0/-0.1}

H397



WEIGHT 76g
SIZE 1.5" Head Tube Reduced to 1-1/8" Fork Tube Threadless Headset
SHIS NORM IS42/28.6 | IS52/39.8(30)

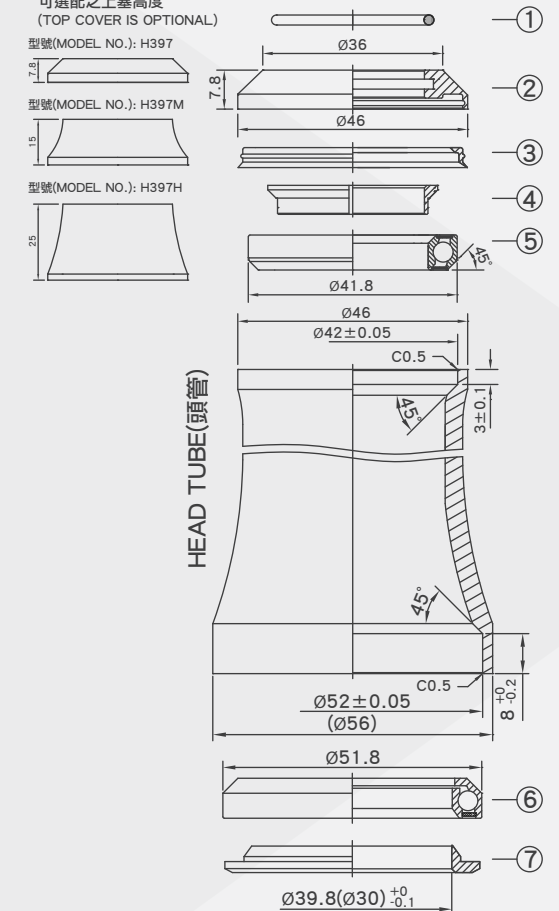

堆積高度(STACK HEIGHT)=9.5 ± 1mm

NO.	零件名稱 PART NAME	材質 MATERIAL	圖號 DRAWING NO.	台量 Q' TY	尺寸 DIM. DESCRIPTION
1	O形圈 O-Ring	橡膠 NBR	120-8	1	ID28.5xØ2
2	上塞 TOP COVER	鋁合金 6061/T6	51-3	1	1-1/8"
3	防塵蓋 UPPER WATER SEAL	橡膠 NBR	273-0	1	
4	鋁斜管 COMPRESSION RING	鋁合金 6061/T6	51-2	1	1-1/8"
5	密封式軸承 A.C. SEALED BEARING	軸承鋼 SUJ2	NHB-6B	1	OD41.8x45°x45°
6	特大卡式軸承 OVERSIZE CARTRIDGE BALL BEARING	軸承鋼 SUJ2	ACB-518	1	OD51.8x36°x45°
7	鋁下塞 CROWN RACE	鋁合金 7075/T6	397-6	1	Ø39.8(Ø30) ^{+0/-0.1}

H398



WEIGHT 76g
 SIZE 1-1/4" Head Tube Reduced to 1-1/8" Fork Tube Threadless Headset
 SHIS NORM IS42/28.6 | IS47.2/33(30)

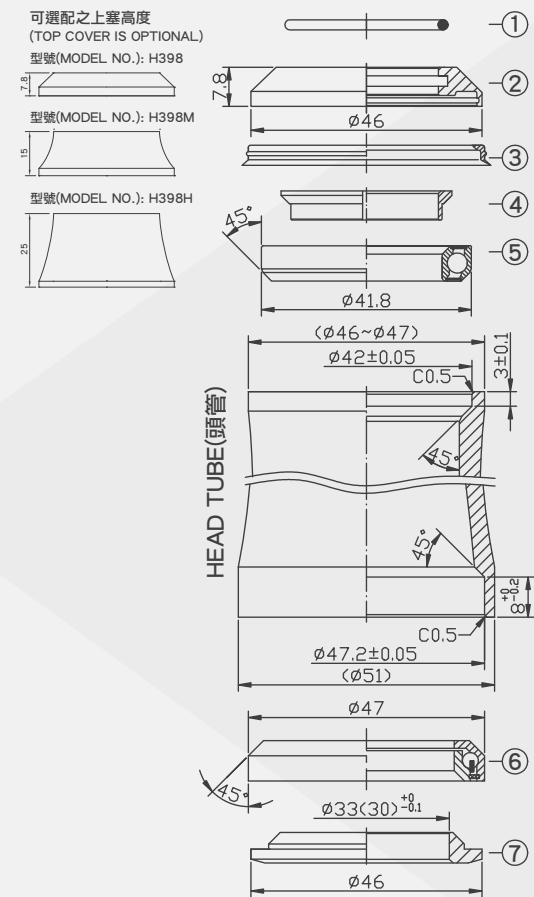

堆積高度(STACK HEIGHT)=9.7±1mm

NO.	零件名稱 PART NAME	材質 MATERIAL	圖號 DRAWING NO.	台量 Q' TY	尺寸 DIM. DESCRIPTION
1	O形圈 O-Ring	橡膠 NBR	120-8	1	ID28.5xØ2
2	上塞 TOP COVER	鋁合金 6061/T6	51-3	1	1-1/8"
3	防塵蓋 UPPER WATER SEAL	橡膠 NBR	273-0	1	
4	鋁斜管 COMPRESSION RING	鋁合金 6061/T6	51-2	1	1-1/8"
5	密封式軸承 A.C. SEALED BEARING	軸承鋼 SUJ2	NHB-6B	1	OD41.8x45"x45"
6	加大型卡式軸承 OVERSIZE CARTRIDGE BALL BEARING	軸承鋼 SUJ2	ACB-47	1	OD47x45"x45"
7	鋁下塞 CROWN RACE	鋁合金 7075/T6	398-6	1	Ø33(Ø30) ^{+0/-0.1}



NECO1 [H299-1]

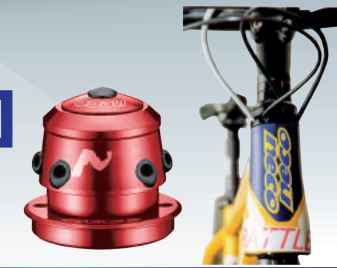

WEIGHT 153g
 SIZE 1-1/8"- 1.5" Front Fork Tube Semi-Integrated Threadless Headset
 SHIS NORM EC44/28.6 | ZS56/30

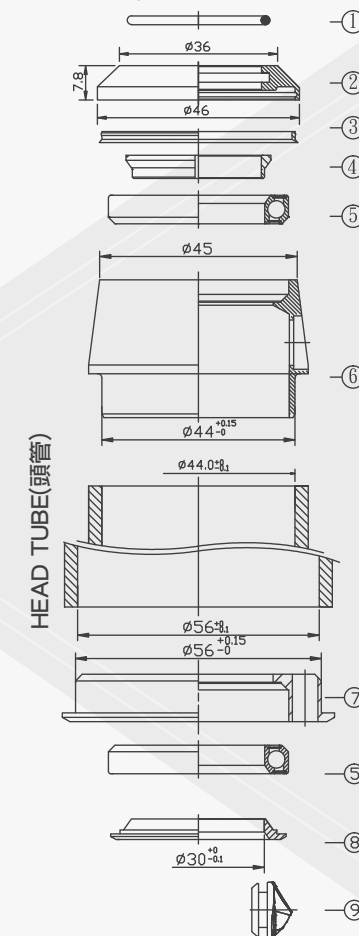

堆積高度(STACK HEIGHT)=32.8±1mm

NO.	零件名稱 PART NAME	材質 MATERIAL	圖號 DRAWING NO.	台量 Q' TY	尺寸 DIM. DESCRIPTION
1	O形圈 O-Ring	橡膠 NBR	120-8	1	ID28.5xØ2
2	上塞 TOP COVER	鋁合金 6061/T6	51-3	1	1-1/8"
3	防塵蓋 DUST-RESISTANT COVER	塑膠 NYLON	273-0	1	
4	鋁斜管 COMPRESSION RING	鋁合金 6061/T6	773-2	1	1-1/8"
5	密封式軸承 AC SEALED BEARING	軸承鋼 SUJ2	NHB-5D	2	OD41x36"x45"
6	上碗 UPPER CUP	鋁合金 6061/T6	299-1-4	1	Ø44 ^{+0.15/-0}
7	下碗 LOWER CUP	鋁合金 6061/T6	299-1-5	1	Ø56 ^{+0.15/-0}
8	下塞 CROWN RACE	鋁合金 6061/T6	123-6	1	Ø30 ^{+0/-0.1}
9	橡膠塞子 RUBBER LID	橡膠 NBR	299-8	4	選配 OPTIONAL

H100

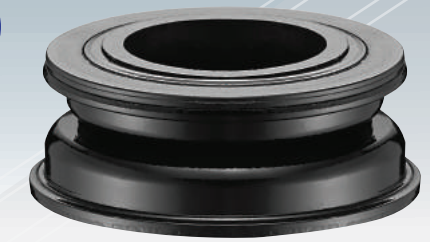

WEIGHT 123g
 SIZE 1-1/4" Head Tube Reduced to 1-1/8" Fork Tube Semi-Integrated Threadless Headset
 SHIS NORM ZS44/28.6 | ZS50.6/30(33)

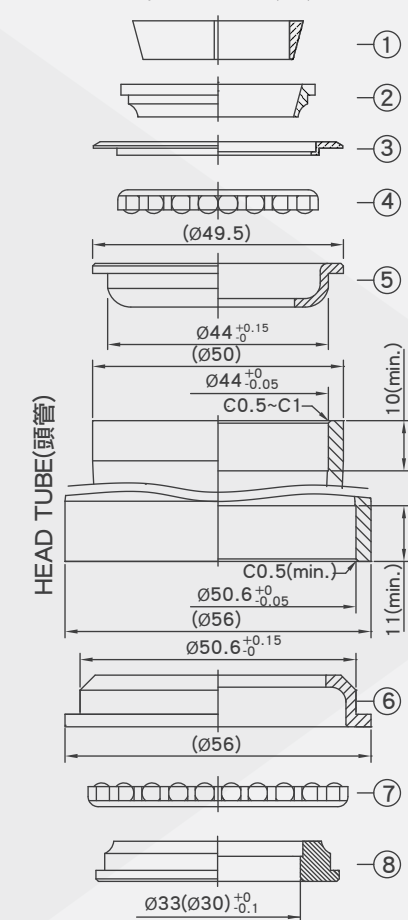

堆積高度(STACK HEIGHT)=8.7±1mm

NO.	零件名稱 PART NAME	材質 MATERIAL	圖號 DRAWING NO.	台量 Q' TY	尺寸 DIM. DESCRIPTION
1	塑膠斜管 COMPRESSION RING	塑膠 NYLON	115-2	1	1-1/8"
2	上塞 TOP COVER	碳鋼 STEEL	115-3	1	1-1/8"
3	塑膠防塵蓋 DUST-RESISTANT COVER	塑膠 NYLON	115-2A	1	
4	珠巢 BALL RETAINER	碳鋼 STEEL		1	5/32"x22
5	上碗 UPPER CUP	碳鋼 STEEL	142-4/5	1	Ø44 ^{+0.15/-0}
6	下碗 LOWER CUP	碳鋼 STEEL	100-5	1	Ø50.6 ^{+0.15/-0}
7	珠巢 BALL RETAINER	碳鋼 STEEL		1	5/32"x25
8	下塞 CROWN RACE	碳鋼 STEEL	100-6	1	Ø33(Ø30) ^{+0/-0.1}

H115M-1 [H115H-1]



WEIGHT M:121g, H:138g
 SIZE 1-1/8" Semi-Integrated Threadless Headset
 SHIS NORM ZS44/28.6 | ZS44/30

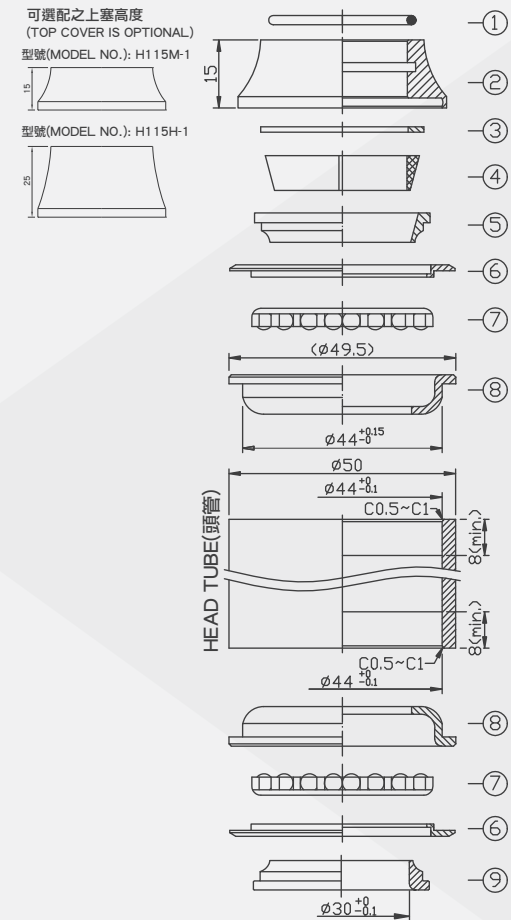

堆積高度(STACK HEIGHT)=23.2±1mm

NO.	零件名稱 PART NAME	材質 MATERIAL	圖號 DRAWING NO.	台量 Q' TY	尺寸 DIM. DESCRIPTION
1	O形圈 O-Ring	橡膠 NBR	120-8	1	ID28.5xØ2
2	鋁上塞 TOP COVER	鋁合金 6061/T6	51M-3	1	1-1/8"
3	墊片 SPACER	碳鋼 STEEL	AS36012	1	1.2txOD36
4	塑膠斜管 COMPRESSION RING	塑膠 NYLON	115-2	1	1-1/8"
5	上塞 TOP COVER	碳鋼 STEEL	115-3	1	1-1/8"
6	塑膠防塵蓋 DUST-RESISTANT COVER	塑膠 NYLON	115-2A	2	
7	珠巢 BALL RETAINER	碳鋼 STEEL		2	5/32"x22
8	上下碗 CLIPS	碳鋼 STEEL	142-4/5	2	Ø44 ^{+0.15} ₋₀
9	下塞 CROWN RACE	碳鋼 STEEL	841-6	1	Ø30 ⁺⁰ _{-0.1}

H117DM [H117DMM]



WEIGHT 106g
 SIZE 1-1/8" Semi-integrated Threadless Headset
 SHIS NORM ZS44/28.6 | ZS44/30

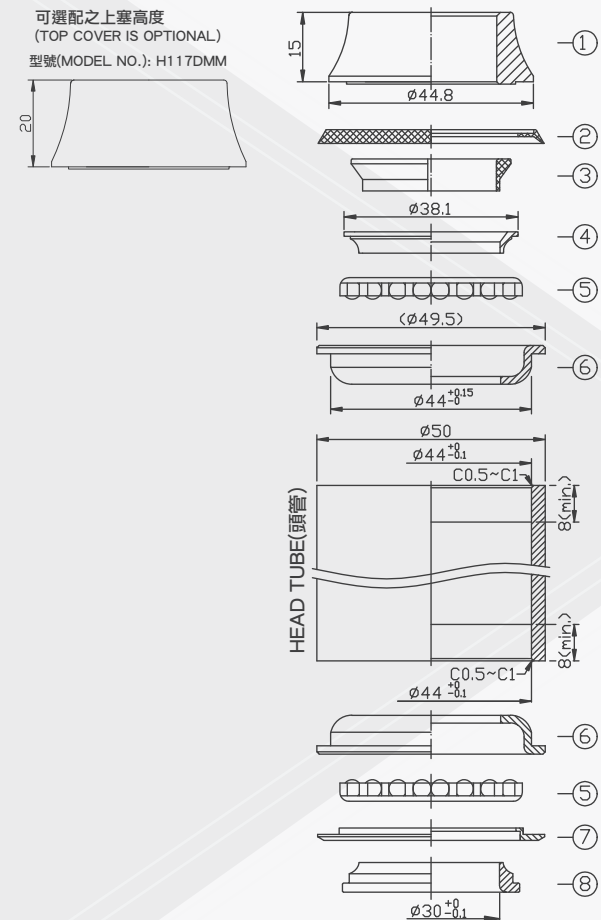

堆積高度(STACK HEIGHT)=23±1mm

NO.	零件名稱 PART NAME	材質 MATERIAL	圖號 DRAWING NO.	台量 Q' TY	尺寸 DIM. DESCRIPTION
1	壓鑄鋁上蓋 DIE CASTING ALLOY COVER	鋁合金 YLD102	117DM-0	1	1-1/8"
2	上防塵套 UPPER DUST-RESISTANT COVER	塑膠 NYLON	118-8	1	
3	塑膠斜管 COMPRESSION RING	塑膠 NYLON	2036	1	1-1/8"
4	上塞 TOP COVER	鉻鉬鋼 CR-MO STEEL	148-4/5-3	1	
5	珠巢 BALL RETAINER	碳鋼 STEEL		2	5/32"x22
6	上下碗 CLIPS	碳鋼 STEEL	142-4/5	2	Ø44 ^{+0.15} ₋₀
7	下防塵套 LOWER DUST-RESISTANT COVER	塑膠 NYLON	115-2A	1	
8	下塞 CROWN RACE	碳鋼 STEEL	841-6	1	Ø30 ⁺⁰ _{-0.1}

H119CDM [119CDMM]



WEIGHT 141.3g
 SIZE 1-1/8" Semi-Integrated Threadless Headset
 SHIS NORM ZS44/28.6 | ZS44/30

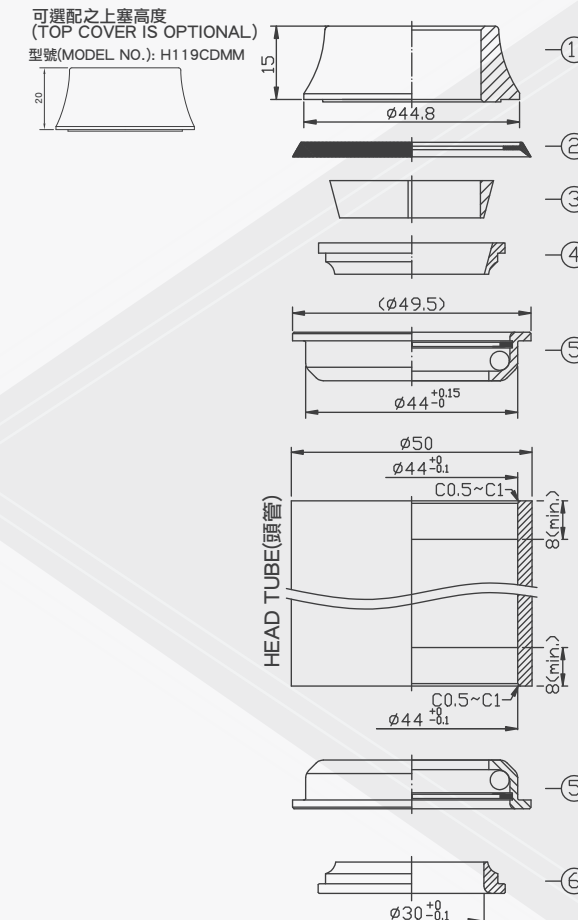

堆積高度(STACK HEIGHT)=21.2±1mm

NO.	零件名稱 PART NAME	材質 MATERIAL	圖號 DRAWING NO.	台量 Q' TY	尺寸 DIM. DESCRIPTION
1	壓鑄鋁上蓋 DIE CASTING ALLOY COVER	鋁合金 YLD102	117DM-0	1	1-1/8"
2	上防塵套 UPPER DUST-RESISTANT COVER	塑膠 NYLON	118-8	1	
3	塑膠斜管 COMPRESSION RING	塑膠 NYLON	115-2	1	1-1/8"
4	上塞 TOP COVER	碳鋼 STEEL	115-3	1	
5	卡式上下碗 CARTRIDGE CLIPS	碳鋼 STEEL	129C-4/5	2	Ø44 ^{+0.15} ₋₀
6	下塞 CROWN RACE	碳鋼 STEEL	841-6	1	Ø30 ⁺⁰ _{-0.1}

H124



WEIGHT 91g
 SIZE 1" Semi-Integrated Threadless Headset
 SHIS NORM ZS44/25.4 | ZS44/27(26.4)

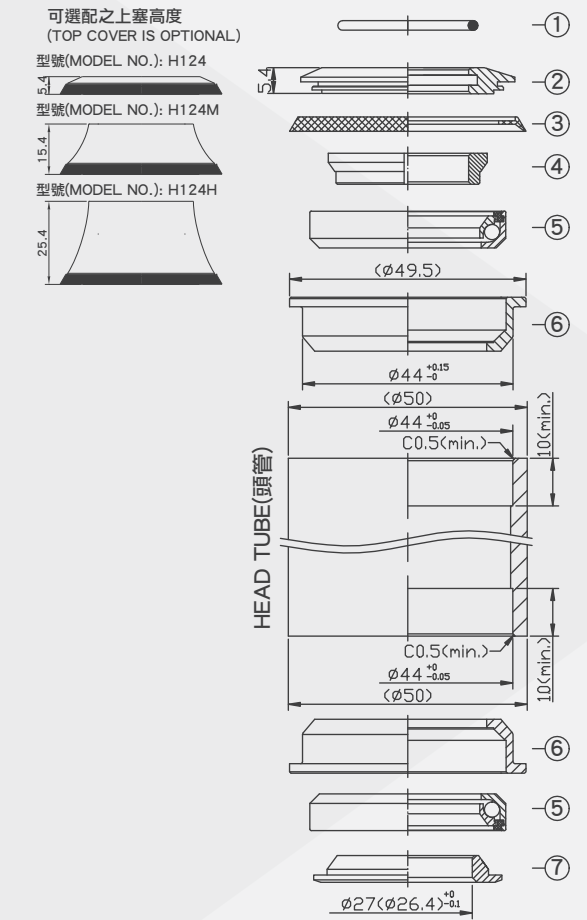

堆積高度(STACK HEIGHT)=10±1mm

NO.	零件名稱 PART NAME	材質 MATERIAL	圖號 DRAWING NO.	台量 Q' TY	尺寸 DIM. DESCRIPTION
1	O形圈 O-Ring	橡膠 NBR	121-8	1	ID25.3xØ2
2	上塞 TOP COVER	鋁合金 6061/T6	124-3	1	1"
3	防塵蓋 DUST-RESISTANT COVER	塑膠 NYLON	118-8	1	
4	鋁斜管 COMPRESSION RING	鋁合金 6061/T6	610-2	1	1"
5	卡式軸承 CARTRIDGE BALL BEARING	鉻鉬鋼 CR-MO STEEL	CBB-41	2	OD41x36"x45"
6	鋁碗 CUPS	鋁合金 6061/T6	125-4/5	2	Ø44 ^{+0.15} ₋₀
7	下塞 CROWN RACE	碳鋼 STEEL	124-6	1	Ø27(Ø26.4) ⁺⁰ _{-0.1}

H125



WEIGHT 60.8g
 SIZE 1-1/8" Semi-Integrated Threadless Headset
 SHIS NORM ZS44/28.6 | ZS44/30

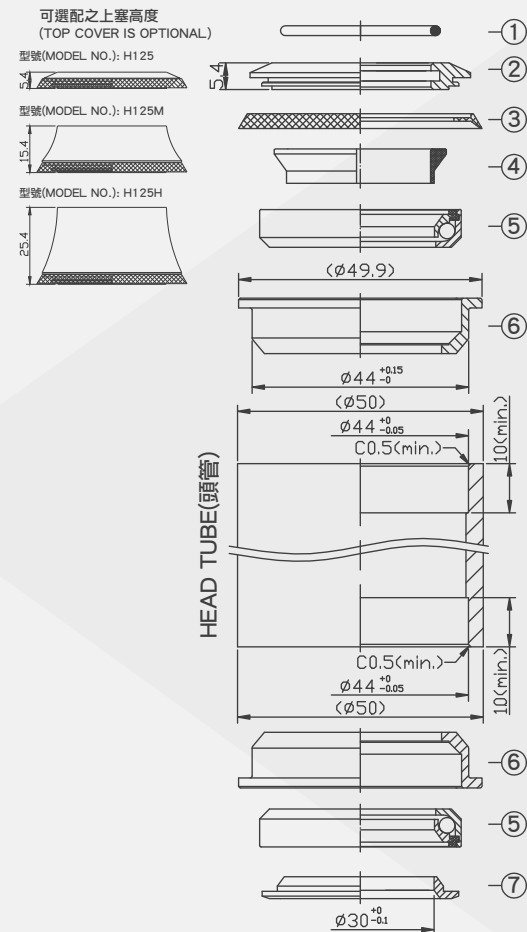

堆積高度(STACK HEIGHT)=10±1mm

NO.	零件名稱 PART NAME	材質 MATERIAL	圖號 DRAWING NO.	台量 Q' TY	尺寸 DIM. DESCRIPTION
1	O形圈 O-Ring	橡膠 NBR	120-8	1	ID28.5xØ2
2	上塞 TOP COVER	鋁合金 6061/T6	125-3	1	1-1/8"
3	防塵蓋 DUST-RESISTANT COVER	塑膠 NYLON	118-8	1	
4	塑膠斜管 COMPRESSION RING	塑膠 NYLON	2036	1	1-1/8"
5	卡式軸承 CARTRIDGE BALL BEARING	鋁鋼 CR-MO STEEL	CBB-41	2	OD41 x 36' x45'
6	鋁碗 CUPS	鋁合金 6061/T6	125-4/5	2	Ø44 ^{+0.15} ₀
7	下塞 CROWN RACE	碳鋼 STEEL	146-6	1	Ø30 ⁺⁰ _{-0.1}

H145



WEIGHT 77g
 SIZE 1-1/8" Semi-Integrated Threadless Headset
 SHIS NORM ZS44/28.6 | ZS44/30

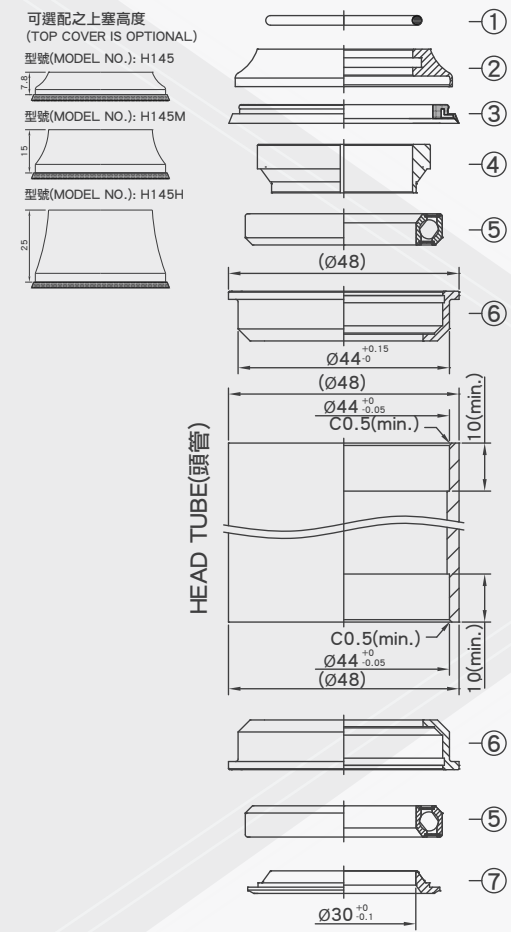

堆積高度(STACK HEIGHT)=14.1±1mm

NO.	零件名稱 PART NAME	材質 MATERIAL	圖號 DRAWING NO.	台量 Q' TY	尺寸 DIM. DESCRIPTION
1	O形圈 O-Ring	橡膠 NBR	120-8	1	ID28.5xØ2
2	上塞 TOP COVER	鋁合金 6061/T6	23-3	1	1-1/8"
3	防塵蓋 DUST-RESISTANT COVER	橡膠 NBR	123-9	1	
4	鋁斜管 COMPRESSION RING	鋁合金 6061/T6	123-2	1	1-1/8"
5	密封式軸承 A.C. SEALED BEARING	軸承鋼 SUJ2	NHB-5D	2	OD41 x 36' x45'
6	鋁碗 CUPS	鋁合金 6061/T6	145-4/5	2	Ø44 ^{+0.15} ₀
7	鋁下塞 CROWN RACE	鋁合金 7075/T6	123-6	1	Ø30 ⁺⁰ _{-0.1}

H146



WEIGHT 77.8g
 SIZE 1-1/8" Semi-Integrated Threadless Headset
 SHIS NORM ZS44/28.6 | ZS44/30

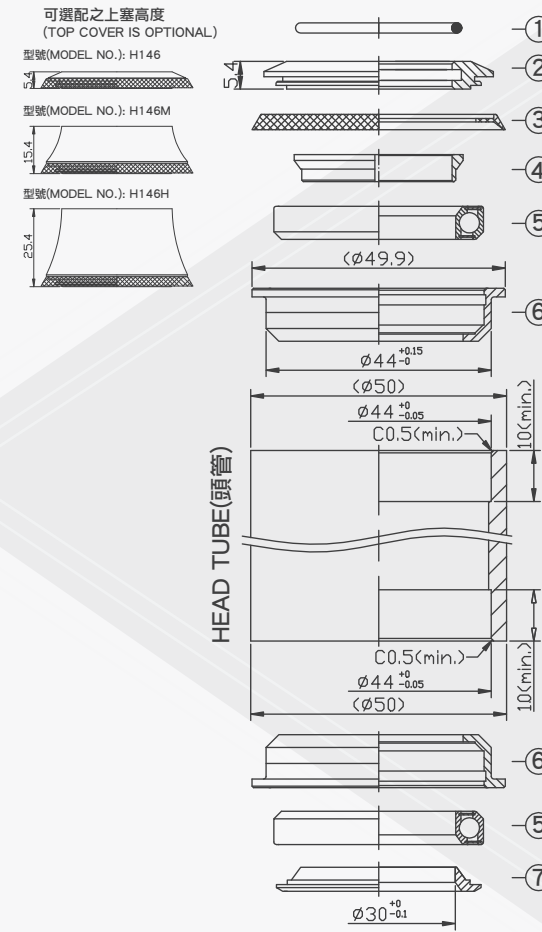

堆積高度(STACK HEIGHT)=9.1±1mm

NO.	零件名稱 PART NAME	材質 MATERIAL	圖號 DRAWING NO.	台量 Q' TY	尺寸 DIM. DESCRIPTION
1	O形圈 O-Ring	橡膠 NBR	120-8	1	ID28.5xØ2
2	上塞 TOP COVER	鋁合金 6061/T6	125-3	1	1-1/8"
3	防塵蓋 DUST-RESISTANT COVER	塑膠 NYLON	118-8	1	
4	鋁斜管 COMPRESSION RING	鋁合金 6061/T6	773-2	1	1-1/8"
5	密封式軸承 A.C. SEALED BEARING	軸承鋼 SUJ2	NHB-5D	2	OD41 x 36' x45'
6	鋁碗 CUPS	鋁合金 6061/T6	146-4/5	2	Ø44 ^{+0.15} ₀
7	鋁下塞 CROWN RACE	鋁合金 7075/T6	123-6	1	Ø30 ⁺⁰ _{-0.1}

H148



WEIGHT 106g
 SIZE 1-1/8" Semi-Integrated Threadless Headset
 SHIS NORM ZS44/28.6 | ZS44/30

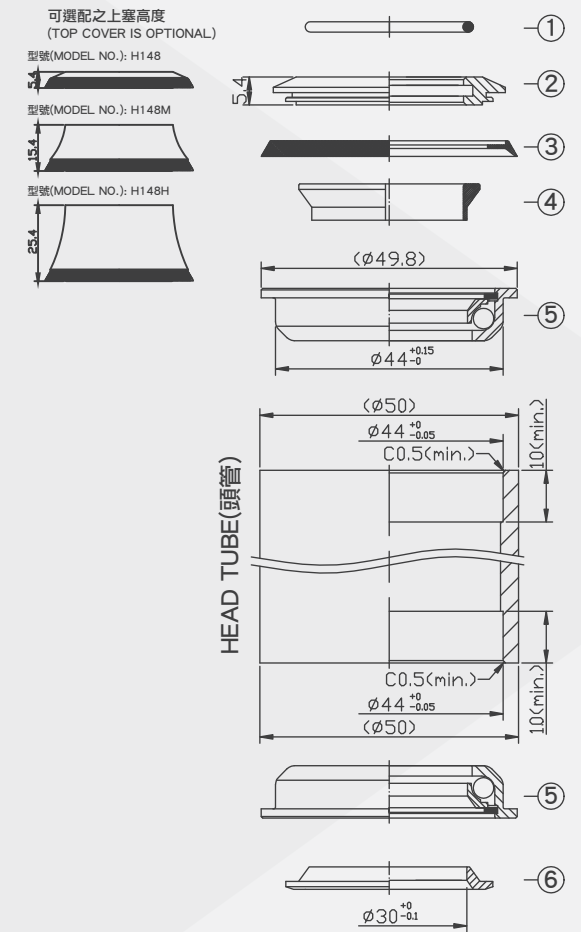

堆積高度(STACK HEIGHT)=9.9±1mm

NO.	零件名稱 PART NAME	材質 MATERIAL	圖號 DRAWING NO.	台量 Q' TY	尺寸 DIM. DESCRIPTION
1	O形圈 O-Ring	橡膠 NBR	120-8	1	ID28.5xØ2
2	上塞 TOP COVER	鋁合金 6061/T6	125-3	1	1-1/8"
3	防塵蓋 DUST-RESISTANT COVER	塑膠 NYLON	118-8	1	
4	塑膠斜管 COMPRESSION RING	塑膠 NYLON	2036	1	1-1/8"
5	卡式碗 CARTRIDGE STEEL CUPS	碳鋼 STEEL	148-4/5	2	Ø44 ^{+0.15} ₀
6	下塞 CROWN RACE	碳鋼 STEEL	146-6	1	Ø30 ⁺⁰ _{-0.1}

H148MP



WEIGHT 103.3g
 SIZE 1-1/8" Semi-Integrated Threadless Headset
 SHIS NORM ZS44/28.6 | ZS44/30

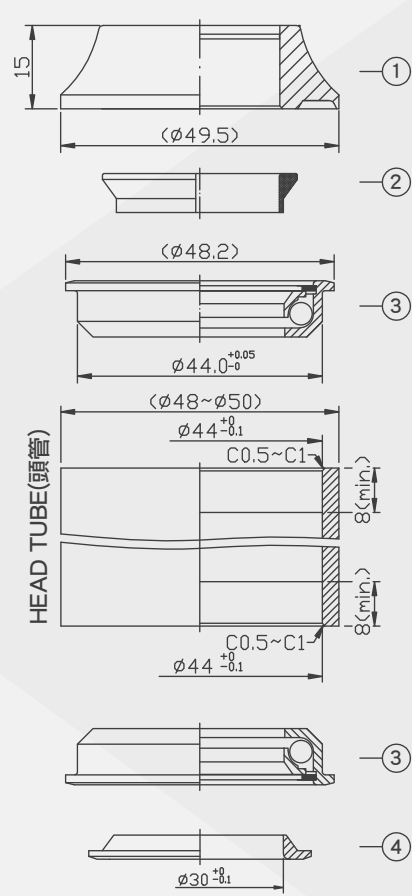

堆積高度(STACK HEIGHT)=19.5±1mm

NO.	零件名稱 PART NAME	材質 MATERIAL	圖號 DRAWING NO.	台量 Q' TY	尺寸 DIM. DESCRIPTION
1	塑膠上蓋 TOP COVER	塑膠 PC	148MP-3	1	1-1/8"
2	塑膠斜管 COMPRESSION RING	塑膠 NYLON	2036	1	1-1/8"
3	半卡式碗 SEMI-CARTRIDGE STEEL CUPS	碳鋼 STEEL	148T-4/5	2	ø44 ^{+0.15} ₋₀
4	下塞 CROWN RACE	碳鋼 STEEL	146-6	1	ø30 ⁺⁰ _{-0.1}

H148DM [H148DMM]



WEIGHT 122.8g
 SIZE 1-1/8" Semi-Integrated Threadless Headset
 SHIS NORM ZS44/28.6 | ZS44/30

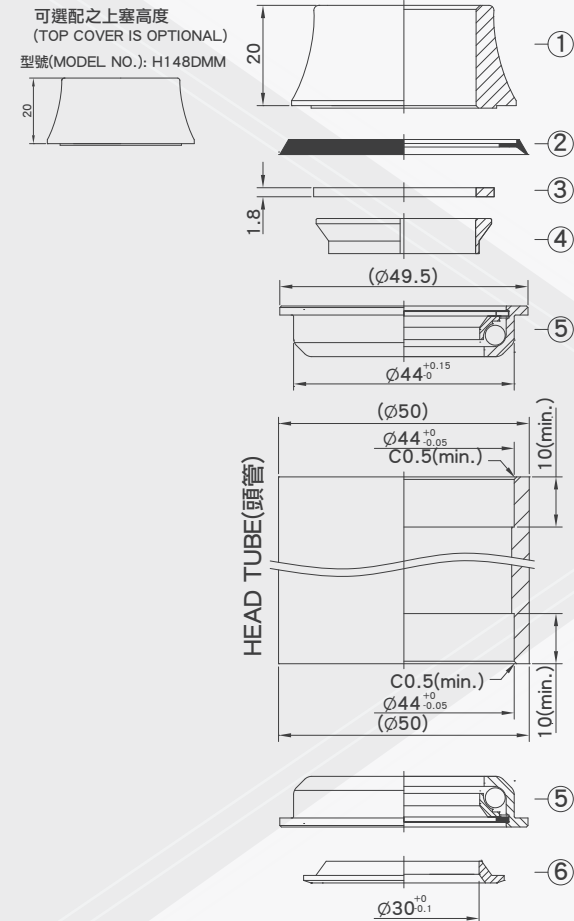

堆積高度(STACK HEIGHT)=26.8±1mm

NO.	零件名稱 PART NAME	材質 MATERIAL	圖號 DRAWING NO.	台量 Q' TY	尺寸 DIM. DESCRIPTION
1	壓鑄鋁上蓋 DIE CASTING ALLOY COVER	鋁合金 YLD102	117DM-0	1	1-1/8"
2	防塵蓋 DUST-RESISTANT COVER	塑膠 NYLON	118-8	1	
3	墊片 SPACER	碳鋼 STEEL	SD36018	1	1/8xøD36(1-1/8")
4	塑膠斜管 COMPRESSION RING	塑膠 NYLON	2036	1	1-1/8"
5	半卡式碗 SEMI-CARTRIDGE CUPS	碳鋼 STEEL	148-4/5	2	ø44 ^{+0.15} ₋₀
6	下塞 CROWN RACE	碳鋼 STEEL	146-6	1	ø30 ⁺⁰ _{-0.1}

H151S



WEIGHT 119g
 SIZE Fits 1-1/8" to 1.5" Tapered Fork Threadless Headset
 SHIS NORM ZS44/28.6 | EC44/39.8(30)

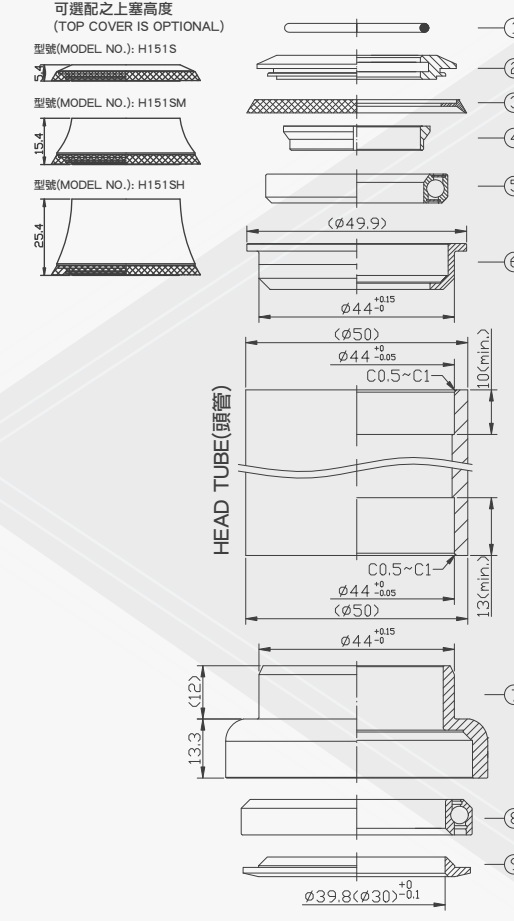

堆積高度(STACK HEIGHT)=20.2±1mm

NO.	零件名稱 PART NAME	材質 MATERIAL	圖號 DRAWING NO.	台量 Q' TY	尺寸 DIM. DESCRIPTION
1	O形圈 O-Ring	橡膠 NBR	120-8	1	ID28.5xø2
2	上塞 TOP COVER	鋁合金 6061/T6	125-3	1	1-1/8"
3	防塵蓋 DUST-RESISTANT COVER	塑膠 NYLON	118-8	1	
4	鋁斜管 DUST-RESISTANT COVER	鋁合金 6061/T6	773-2	1	1-1/8"
5	密封式軸承 A.C. SEALED BEARING	軸承鋼 SUJ2	NHB-5D	1	OD 41 x 36" x 45"
6	鋁上碗 UPPER CUP	鋁合金 6061/T6	146-4/5	1	ø44 ^{+0.15} ₋₀
7	鋁下碗 LOWER CUP	鋁合金 6061/T6	151S-5	1	ø44 ^{+0.15} ₋₀
8	特大密封式軸承 OVERSIZE A.C. SEALED BEARING	軸承鋼 SUJ2	NHB-15	1	OD 52 x 45" x 45"
9	鋁下塞 CROWN RACE	鋁合金 7075/T6	151-6 (153-6)	1	ø39.8(ø30) ⁺⁰ _{-0.1}

H156 [H156E]



WEIGHT 134g
 SIZE 1.5" Head Tube Reduced to 1-1/8" Fork Tube Semi-Integrated Threadless Headset
 SHIS NORM ZS44/28.6 | ZS55/39.8(30)

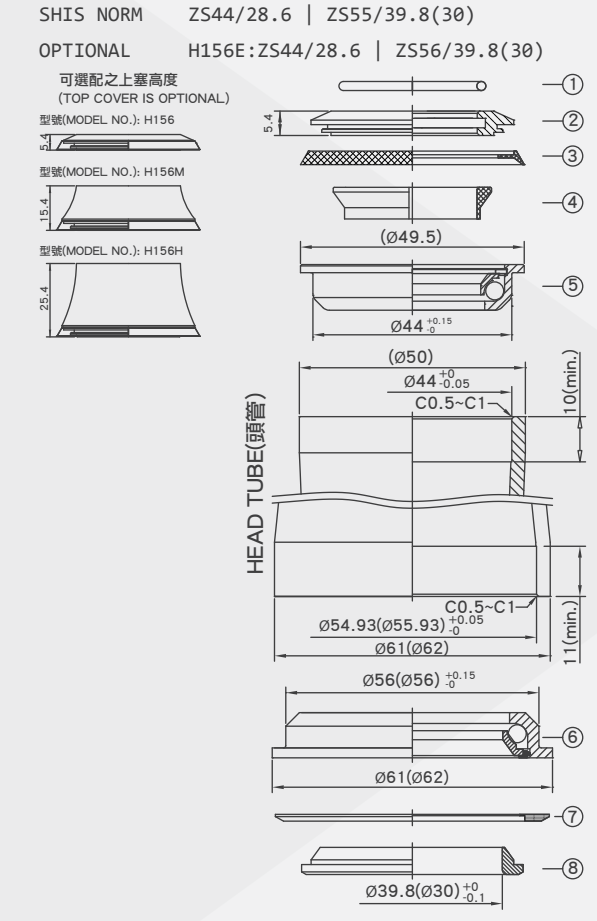

堆積高度(STACK HEIGHT)=11.8±1mm

NO.	零件名稱 PART NAME	材質 MATERIAL	圖號 DRAWING NO.	台量 Q' TY	尺寸 DIM. DESCRIPTION
1	O形圈 O-Ring	橡膠 NBR	120-8	1	ID28.5xø2
2	上塞 TOP COVER	鋁合金 6061/T6	125-3	1	1-1/8"
3	防塵蓋 DUST-RESISTANT COVER	塑膠 NYLON	118-8	1	
4	塑膠斜管 COMPRESSION RING	塑膠 NYLON	2036	1	1-1/8"
5	半卡式上碗 SEMI-CARTRIDGE STEEL UPPER CUP	碳鋼 STEEL	148-4/5	1	ø44 ^{+0.15} ₋₀
6	半卡式下碗 SEMI-CARTRIDGE STEEL LOWER CUP	碳鋼 STEEL	156-5 (156E-5)	1	ø55(ø56) ^{+0.15} ₋₀
7	下防塵蓋 LOWER DUST-RESISTANT COVER	塑膠 NYLON	156-8	1	
8	下塞 CROWN RACE	碳鋼 STEEL	156-6	1	ø39.8(ø30) ⁺⁰ _{-0.1}

H156MP [H156EMP]



WEIGHT 133g
SIZE 1.5" Head Tube Reduced to 1-1/8"
Fork Tube Semi-Integrated Threadless Headset
SHIS NORM ZS44/28.6 | ZS55/39.8(30)
OPTIONAL H156EMP:ZS44/28.6 | ZS56/39.8(30)

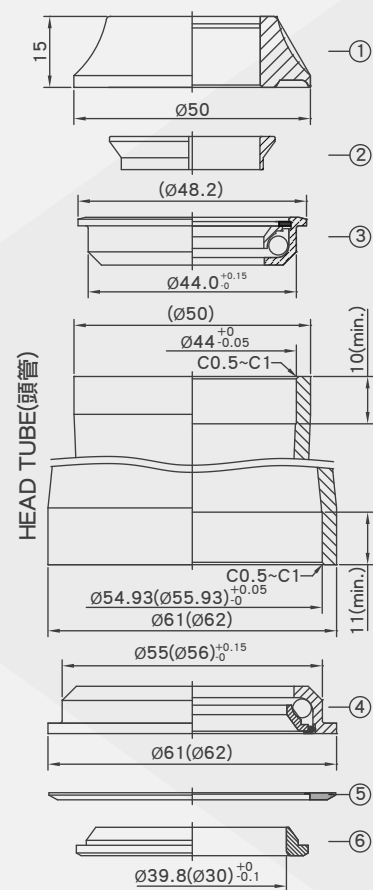

堆積高度(STACK HEIGHT)=21.4±1mm

NO.	零件名稱 PART NAME	材質 MATERIAL	圖號 DRAWING NO.	台量 Q' TY	尺寸 DIM. DESCRIPTION
1	塑膠上蓋 TOP COVER	塑膠 PC	148MP-3	1	1-1/8"
2	塑膠斜管 COMPRESSION RING	塑膠 NYLON	2036	1	1-1/8"
3	半卡式上碗 SEMI-CARTRIDGE STEEL UPPER CUP	碳鋼 STEEL	148T-4	1	Ø44 ^{+0.15}
4	半卡式下碗 SEMI-CARTRIDGE STEEL LOWER CUP	碳鋼 STEEL	156-5 (156E-5)	1	Ø55(Ø56) ^{+0.15}
5	下防塵蓋 LOWER DUST-RESISTANT COVER	塑膠 NYLON	156-8	1	
6	下塞 CROWN RACE	碳鋼 STEEL	156-6	1	Ø39.8(Ø30) ^{+0.1}

H159 [H159E]



WEIGHT 127g
SIZE 1.5" Head Tube Reduced to 1-1/8" Fork Tube
Semi-Integrated Threadless Headset
SHIS NORM ZS44/28.6 | ZS55/39.8(30)
OPTIONAL H159E:ZS44/28.6 | ZS56/39.8(30)

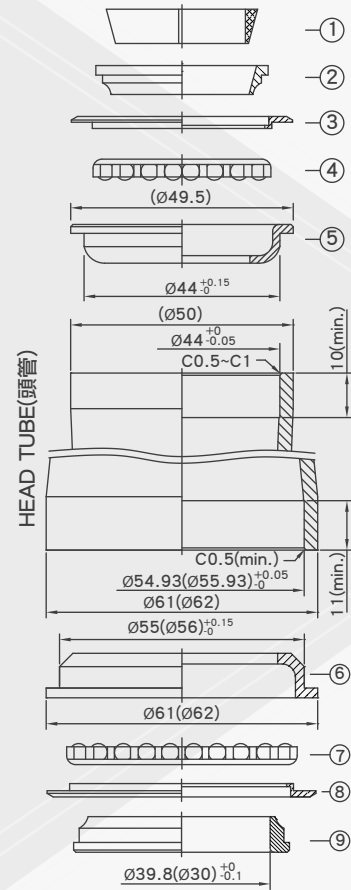

堆積高度(STACK HEIGHT)=10.1±1mm

NO.	零件名稱 PART NAME	材質 MATERIAL	圖號 DRAWING NO.	台量 Q' TY	尺寸 DIM. DESCRIPTION
1	塑膠斜管 COMPRESSION RING	塑膠 NYLON	115-2	1	1-1/8"
2	上塞 TOP COVER	碳鋼 STEEL	115-3	1	1-1/8"
3	防塵蓋 DUST-RESISTANT COVER	塑膠 NYLON	115-2A	1	
4	珠巢 BALL RETAINER	碳鋼 STEEL		1	5/32"x22
5	上碗 UPPER CUP	碳鋼 STEEL	115-4	1	Ø44 ^{+0.15}
6	下碗 LOWER CUP	碳鋼 STEEL	159-5 (159E-5)	1	Ø55(Ø56) ^{+0.15}
7	珠巢 BALL RETAINER	碳鋼 STEEL		1	5/32"x27
8	下防塵蓋 LOWER DUST-RESISTANT COVER	塑膠 NYLON	159-8	1	
9	下塞 CROWN RACE	碳鋼 STEEL	159-6	1	Ø39.8(Ø30) ^{+0.1}

H162



WEIGHT 82g
SIZE 1" Semi-Integrated Threadless Headset
SHIS NORM ZS44/25.4 | ZS44/27(26.4)

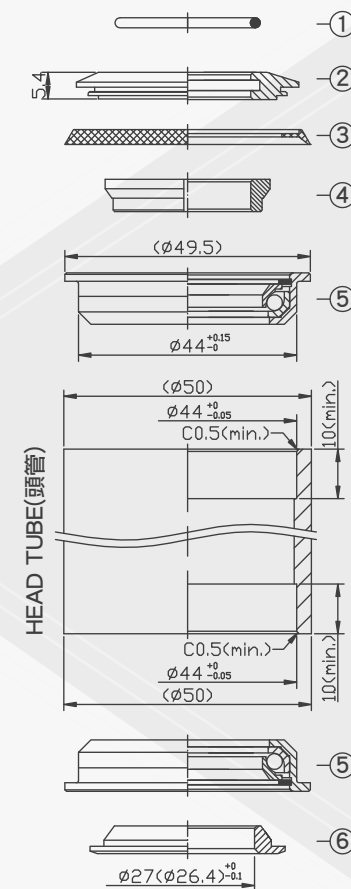

堆積高度(STACK HEIGHT)=9.1±1mm

NO.	零件名稱 PART NAME	材質 MATERIAL	圖號 DRAWING NO.	台量 Q' TY	尺寸 DIM. DESCRIPTION
1	O形圈 O-Ring	橡膠 NBR	121-8	1	ID25.3xØ2
2	上塞 TOP COVER	鋁合金 6061/T6	124-3	1	1"
3	防塵蓋 DUST-RESISTANT COVER	塑膠 NYLON	118-8	1	
4	鋁斜管 COMPRESSION RING	鋁合金 6061/T6	610-2	1	1"
5	半卡式鋁碗 SEMI-CARTRIDGE ALLOY CUPS	鋁合金+合金鋼 6061/T6+CR-MO	172-4/5	2	Ø44 ^{+0.15}
6	下塞 CROWN RACE	碳鋼 STEEL	124-6	1	Ø27(Ø26.4) ^{+0.1}

H172



WEIGHT 75g
SIZE 1-1/8" Semi-Integrated Threadless Headset
SHIS NORM ZS44/28.6 | ZS44/30

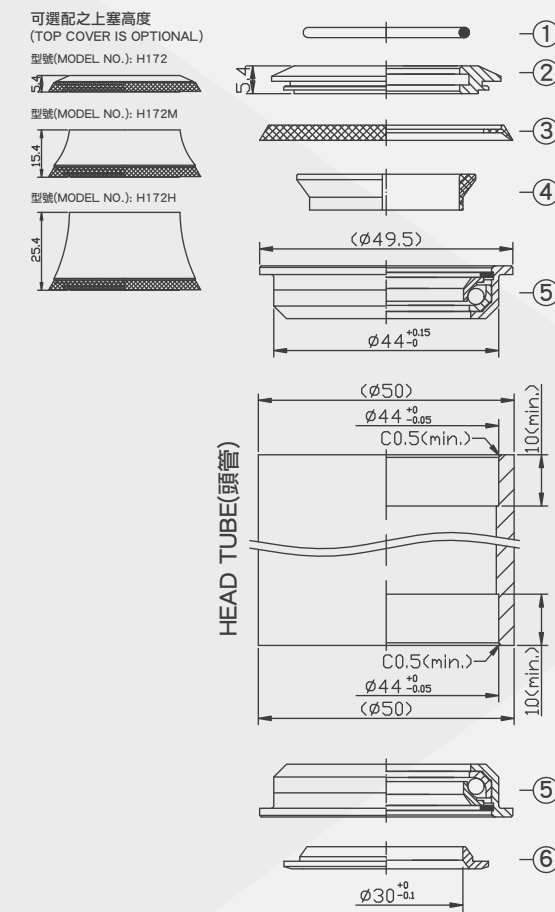

堆積高度(STACK HEIGHT)=9.1±1mm

NO.	零件名稱 PART NAME	材質 MATERIAL	圖號 DRAWING NO.	台量 Q' TY	尺寸 DIM. DESCRIPTION
1	O形圈 O-Ring	橡膠 NBR	120-8	1	ID28.5xØ2
2	上塞 TOP COVER	鋁合金 6061/T6	125-3	1	1-1/8"
3	防塵蓋 DUST-RESISTANT COVER	塑膠 NYLON	118-8	1	
4	塑膠斜管 COMPRESSION RING	塑膠 NYLON	2036	1	1-1/8"
5	半卡式鋁碗 SEMI-CARTRIDGE ALLOY CUPS	鋁合金+合金鋼 6061/T6+CR-MO	172-4/5	2	Ø44 ^{+0.15}
6	下塞 CROWN RACE	碳鋼 STEEL	146-6	1	Ø30 ^{+0.1}

H176



WEIGHT 112g
 SIZE 1-1/8" Semi-Integrated Threadless Headset
 SHIS NORM ZS44/28.6 | ZS44/30

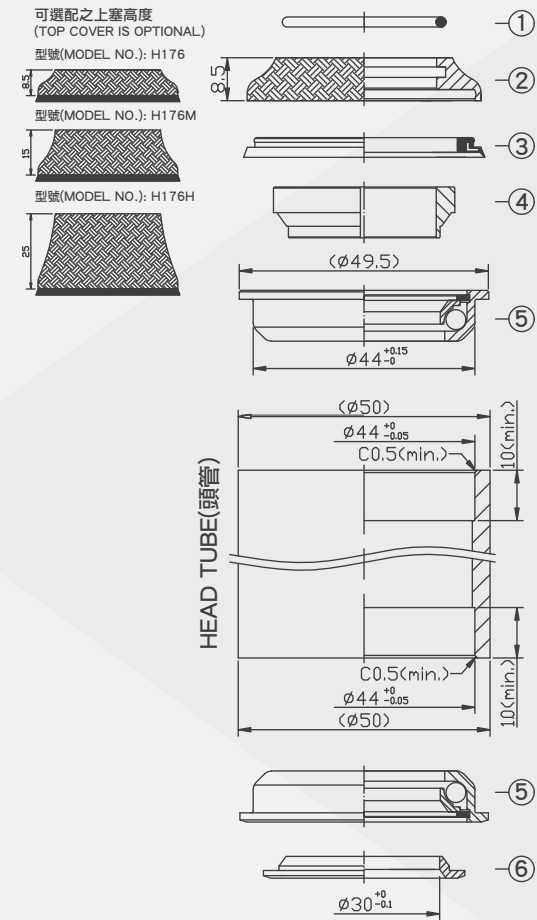

堆積高度(STACK HEIGHT)=14.6±1mm

NO.	零件名稱 PART NAME	材質 MATERIAL	圖號 DRAWING NO.	台量 Q' TY	尺寸 DIM. DESCRIPTION
1	O形圈 O-Ring	橡膠 NBR	120-8	1	ID28.5xØ2
2	上塞 TOP COVER	碳纖維 CARBON FIBER	22-3	1	1-1/8"
3	防塵蓋 DUST-RESISTANT COVER	塑膠 NYLON	123-9	1	
4	鋁斜管 COMPRESSION RING	鋁合金 6061/T6	123-2	1	1-1/8"
5	半卡式碗 SEMI-CARTRIDGE STEEL CUPS	碳鋼 STEEL	148-4/5	2	Ø44 ^{+0.15} ₋₀
6	下塞 CROWN RACE	碳鋼 STEEL	146-6	1	Ø30 ⁺⁰ _{-0.1}

H180



WEIGHT 75g
 SIZE 1-1/8" Semi-Integrated Threadless Headset
 SHIS NORM ZS44/28.6 | ZS44/30

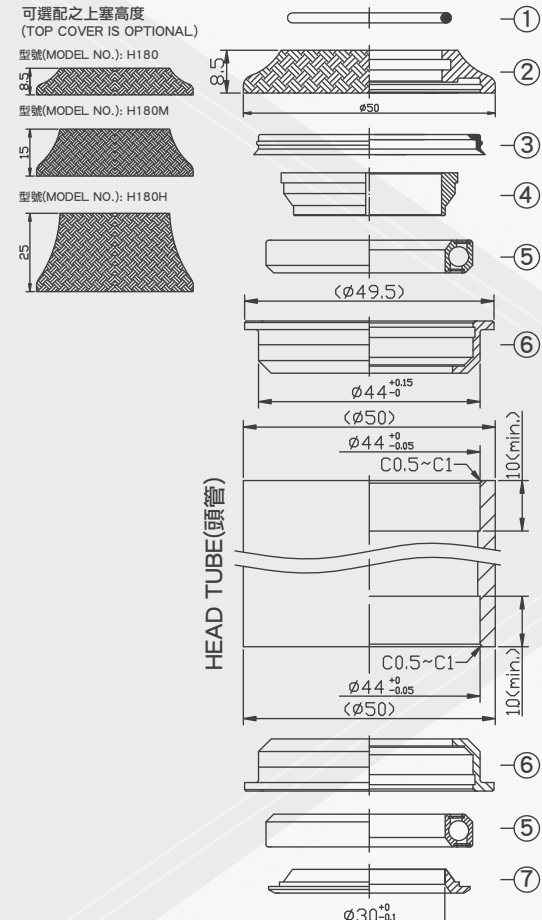

堆積高度(STACK HEIGHT)=13.7±1mm

NO.	零件名稱 PART NAME	材質 MATERIAL	圖號 DRAWING NO.	台量 Q' TY	尺寸 DIM. DESCRIPTION
1	O形圈 O-Ring	橡膠 NBR	120-8	1	ID28.5xØ2
2	上塞 TOP COVER	碳纖維 CARBON FIBER	180-3	1	1-1/8"
3	防塵蓋 DUST-RESISTANT COVER	橡膠 NBR	273-0	1	
4	鋁斜管 COMPRESSION RING	鋁合金 6061/T6	180-2	1	1-1/8"
5	密封式軸承 A.C. SEALED BEARING	軸承鋼 SUJ2	NHB-5D	2	OD 41 x 36 x 45"
6	鋁碗 CUPS	鋁合金 6061/T6	146-4/5	2	Ø44 ^{+0.15} ₋₀
7	鋁下塞 CROWN RACE	鋁合金 7075/T6	123-6	1	Ø30 ⁺⁰ _{-0.1}

H185



WEIGHT 98g
 SIZE 1-1/8" Semi-Integrated Threadless Headset
 SHIS NORM ZS44/28.6 | ZS44/30

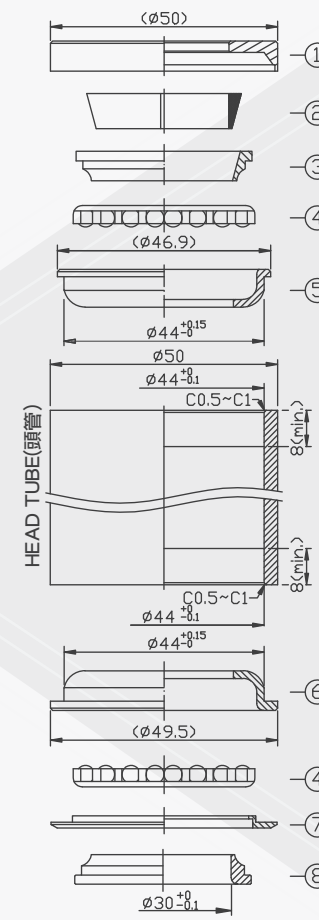

堆積高度(STACK HEIGHT)=11.7±1mm

NO.	零件名稱 PART NAME	材質 MATERIAL	圖號 DRAWING NO.	台量 Q' TY	尺寸 DIM. DESCRIPTION
1	鋁上蓋 TOP COVER	鋁合金 6061/T6	185-1	1	1-1/8"
2	塑膠斜管 COMPRESSION RING	塑膠 NYLON	115-2	1	1-1/8"
3	上塞 TOP COVER	碳鋼 STEEL	115-3	1	1-1/8"
4	珠巢 BALL RETAINER	碳鋼 STEEL		2	5/32x22
5	上碗 UPPER CUP	碳鋼 STEEL	184-4	1	Ø44 ^{+0.15} ₋₀
6	下碗 LOWER CUP	碳鋼 STEEL	142-4/5	1	Ø44 ^{+0.15} ₋₀
7	塑膠防塵蓋 DUST-RESISTANT COVER	塑膠 NYLON	115-2A	1	
8	下塞 CROWN RACE	碳鋼 STEEL	841-6	1	Ø30 ⁺⁰ _{-0.1}

H187



WEIGHT 130g
 SIZE 1-1/4" Head Tube Reduced to 1-1/8"
 Fork Tube Semi-Integrated Threadless Headset
 SHIS NORM ZS44/28.6 | ZS50.6/33(30)

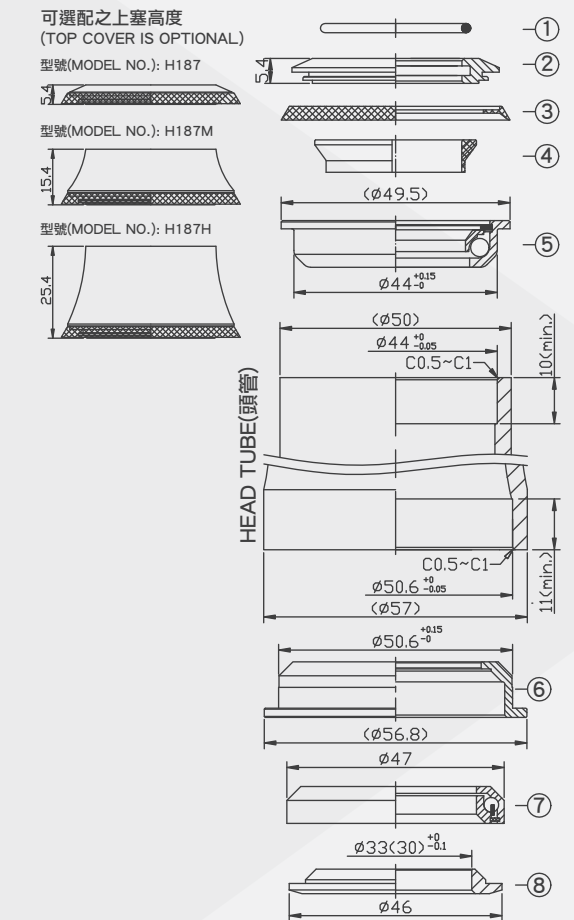

堆積高度(STACK HEIGHT)=9.9±1mm

NO.	零件名稱 PART NAME	材質 MATERIAL	圖號 DRAWING NO.	台量 Q' TY	尺寸 DIM. DESCRIPTION
1	O形圈 O-Ring	橡膠 NBR	120-8	1	ID28.5xØ2
2	上塞 TOP COVER	鋁合金 6061/T6	125-3	1	1-1/8"
3	防塵蓋 DUST-RESISTANT COVER	塑膠 NYLON	118-8	1	
4	塑膠斜管 COMPRESSION RING	塑膠 NYLON	2036	1	1-1/8"
5	半卡式碗 SEMI-CARTRIDGE CUP	碳鋼 STEEL	148-4/5	1	Ø44 ^{+0.15} ₋₀
6	下碗 LOWER CUP	鋁合金 6061/T6	187-5	1	Ø50.6 ^{+0.15} ₋₀
7	加大型卡式軸承 OVERSIZE CARTRIDGE BALL BEARING	軸承鋼 SUJ2	ACB-47	1	OD47 x 45 x 45"
8	下塞 CROWN RACE	碳鋼 STEEL	187-6	1	Ø33(30) ^{+0.1} ₋₀

H188



WEIGHT 106g
 SIZE 1-1/4" Head Tube Reduced to 1-1/8"
 Fork Tube Semi-Integrated Threadless Headset
 SHIS NORM ZS44.28.6 | ZS50.6/33(30)

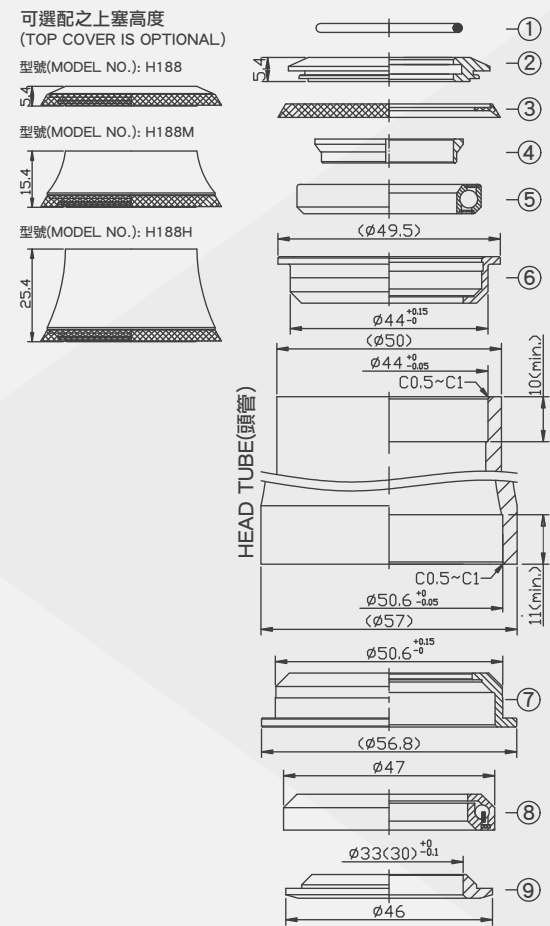

堆積高度(STACK HEIGHT)=9.2±1mm

NO.	零件名稱 PART NAME	材質 MATERIAL	圖號 DRAWING NO.	台量 Q' TY	尺寸 DIM. DESCRIPTION
1	O形圈 O-Ring	橡膠 NBR	120-8	1	ID28.5xØ2
2	上塞 TOP COVER	鋁合金 6061/T6	125-3	1	1-1/8"
3	防塵蓋 DUST-RESISTANT COVER	塑膠 NYLON	118-8	1	
4	鋁斜管 COMPRESSION RING	鋁合金 6061/T6	773-2	1	1-1/8"
5	密封式軸承 A.C. SEALED BEARING	軸承鋼 SUJ2	NHB-5D	1	OD41×36°x45°
6	上碗 UPPER CUP	鋁合金 6061/T6	146-4/5	1	Ø44 ^{+0.15}
7	下碗 LOWER CUP	鋁合金 6061/T6	187-5	1	Ø50.6 ^{+0.15}
8	加大型卡式軸承 OVERSIZE CARTRIDGE BALL BEARING	軸承鋼 SUJ2	ACB-47	1	OD47×45°x45°
9	下塞 CROWN RACE	碳鋼 STEEL	187-6	1	Ø33(30) ^{+0.1}

H189



WEIGHT 102g
 SIZE 1-1/4" Reduced to 1-1/8"
 Fork Tube Semi-Integrated Threadless Headset
 SHIS NORM ZS41.4/28.6 | ZS50.6/33(30)

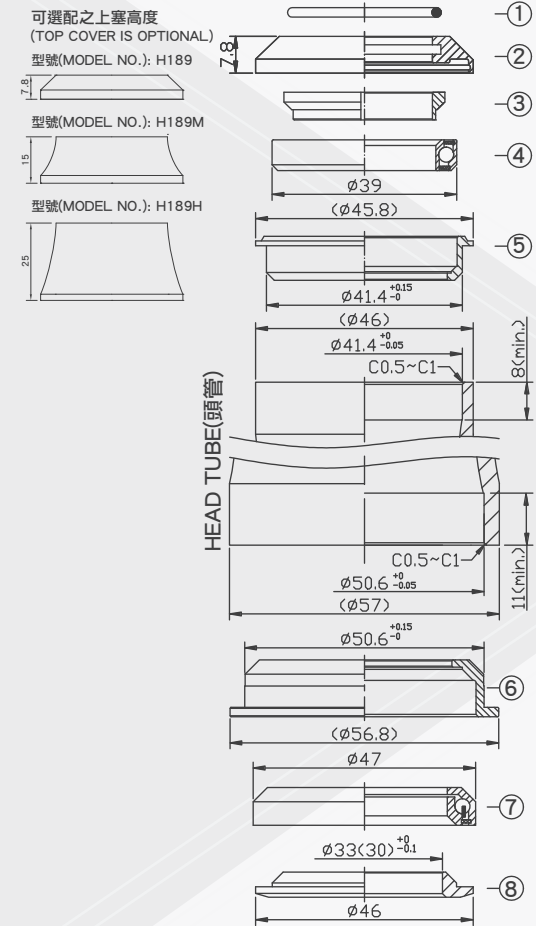

堆積高度(STACK HEIGHT)=12.2±1mm

NO.	零件名稱 PART NAME	材質 MATERIAL	圖號 DRAWING NO.	台量 Q' TY	尺寸 DIM. DESCRIPTION
1	O形圈 O-Ring	橡膠 NBR	120-8	1	ID28.5xØ2
2	上塞 TOP COVER	鋁合金 6061/T6	51-3	1	1-1/8"
3	鋁斜管 COMPRESSION RING	鋁合金 6061/T6	52-2	1	1-1/8"
4	密封式軸承 A.C. SEALED BEARING	軸承鋼 SUJ2	NHB-6S	1	OD39×45°x45°
5	上碗 UPPER CUP	鋁合金 6061/T6	189-4	1	Ø41.4 ^{+0.15}
6	下碗 LOWER CUP	鋁合金 6061/T6	187-5	1	Ø50.6 ^{+0.15}
7	加大型卡式軸承 OVERSIZE CARTRIDGE BALL BEARING	軸承鋼 SUJ2	ACB-47	1	OD47×45°x45°
8	下塞 CROWN RACE	碳鋼 STEEL	187-6	1	Ø33(30) ^{+0.1}

H332L

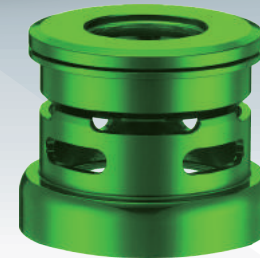

WEIGHT 145g
 SIZE 1.5" Head Tube Reduced to 1-1/8"
 Fork Tube Semi-Integrated + External Cup
 Threadless Headset
 SHIS NORM ZS49.7/28.6 | EC49.7 /39.8(30)

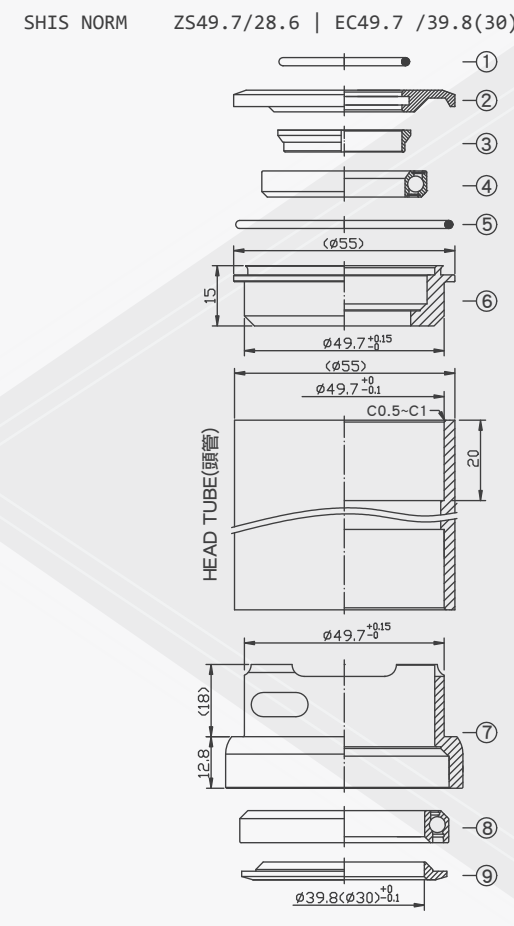

堆積高度(STACK HEIGHT)=20.3±1mm

NO.	零件名稱 PART NAME	材質 MATERIAL	圖號 DRAWING NO.	台量 Q' TY	尺寸 DIM. DESCRIPTION
1	O形圈 O-Ring	橡膠 NBR	120-8	1	ID28.5xØ2
2	鋁上塞 TOP COVER	鋁合金 6061/T6	323-3	1	1-1/8"
3	鋁斜管 COMPRESSION RING	鋁合金 6061/T6	773-2	1	1-1/8"
4	密封式軸承 A.C. SEALED BEARING	軸承鋼 SUJ2	NHB-5D	1	OD41×36°x45°
5	O形圈 O-Ring	橡膠 NBR	332-8	1	ID47.5xØ2
6	上碗 UPPER CUP	鋁合金 6061/T6	332-4	1	Ø49.7 ^{+0.15}
7	下碗 LOWER CUP	鋁合金 6061/T6	151A-5	1	Ø49.7 ^{+0.15}
8	特大密封式軸承 OVERSIZE A.C. SEALED BEARING	軸承鋼 SUJ2	NHB-15	1	OD52×45°x45°
9	鋁下塞 CROWN RACE	鋁合金 6061/T6	151-6 (153-6)	1	Ø39.8(30) ^{+0.1}

H369-3



WEIGHT 70g
 SIZE 1-1/8" Semi-Integrated Threadless Headset
 SHIS NORM ZS41.4/28.6 | ZS41.4 /30

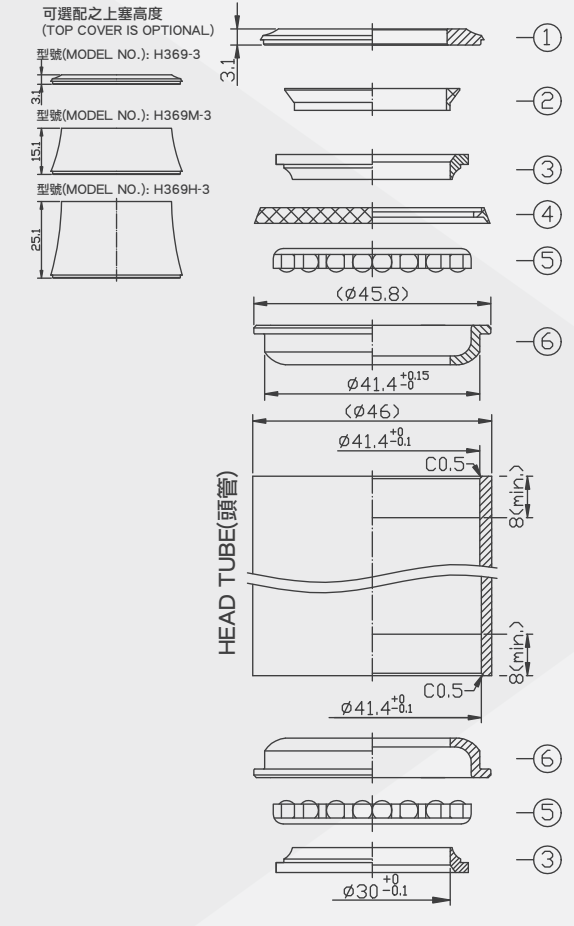

堆積高度(STACK HEIGHT)=9.7±1mm

NO.	零件名稱 PART NAME	材質 MATERIAL	圖號 DRAWING NO.	台量 Q' TY	尺寸 DIM. DESCRIPTION
1	鋁蓋 TOP COVER	鋁合金 6061/T6	369-3-1	1	1-1/8"
2	塑膠斜管 COMPRESSION RING	塑膠 NYLON	701-2	1	1-1/8"
3	上下塞 TOP & LOWER CONE	碳鋼 STEEL	369-3-6	2	Ø30 ^{+0.1}
4	防塵蓋 DUST-RESISTANT COVER	塑膠 NYLON	141-8	1	
5	珠巢 BALL RETAINER	碳鋼 STEEL		2	1/8"×23
6	上下碗 CUPS	碳鋼 STEEL	141-4/5	2	Ø41.4 ^{+0.15}

H383 H384 [H383A] [H384A]



WEIGHT 106g
 SIZE 1.5" Head Tube Reduced to 1-1/8"
 Fork Tube Semi-Integrated Threadless Headset
 SHIS NORM ZS44/28.6 | ZS55/39.8 (H383)
 OPTIONAL H384 #6 Crown Race ID:30.0mm
 SHIS NORM ZS44/28.6 | ZS55/30(H384)
 OPTIONAL MATERIAL H383A/H384A :Alloy lower cup and

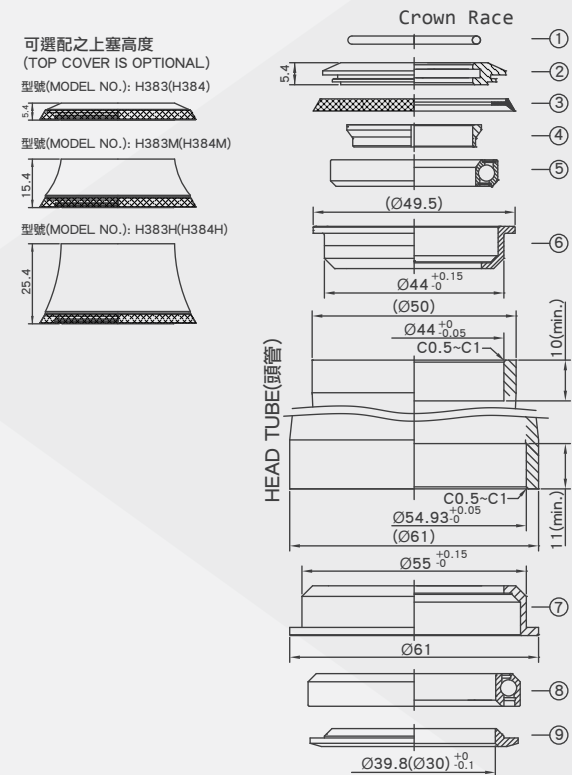

堆積高度(STACK HEIGHT)=9.5±1mm

NO.	零件名稱 PART NAME	材質 MATERIAL	圖號 DRAWING NO.	台量 QTY	尺寸 DIM. DESCRIPTION
1	O形圈 O-Ring	橡膠 NBR	120-8	1	ID28.5xØ2
2	上塞 TOP COVER	鋁合金 6061/T6	125-3	1	1-1/8"
3	防塵蓋 DUST-RESISTANT COVER	塑膠 NYLON	118-8	1	
4	鋁斜管 COMPRESSION RING	鋁合金 6061/T6	773-2	1	1-1/8"
5	密封式軸承 A.C. SEALED BEARING	軸承鋼 SUJ2	NHB-5D	1	OD41 x 36" x45"
6	上碗 UPPER CUP	鋁合金 6061/T6	146-4/5	1	Ø44 ^{+0.15} / ₀
7	下碗 LOWER CUP	碳鋼 STEEL	383-5	1	Ø55 ^{+0.15} / ₀
8	特大密封式軸承 OVERSIZE A.C. SEALED BEARING	軸承鋼 SUJ2	NHB-15	1	OD52 x 45" x45"
9	下塞 CROWN RACE	碳鋼 STEEL	151S-6 (153S-6)	1	Ø39.8(Ø30) ^{+0.1} / _{-0.1}

H383AE [H384AE]



WEIGHT 106g
 SIZE 1.5" Head Tube Reduced to 1-1/8"
 Fork Tube Semi-Integrated Threadless Headset
 SHIS NORM ZS44/28.6 | ZS56/39.8(H383AE)
 OPTIONAL H384AE #6 Crown Race ID:30.0mm
 SHIS NORM ZS44/28.6 | ZS56/30(H384AE)

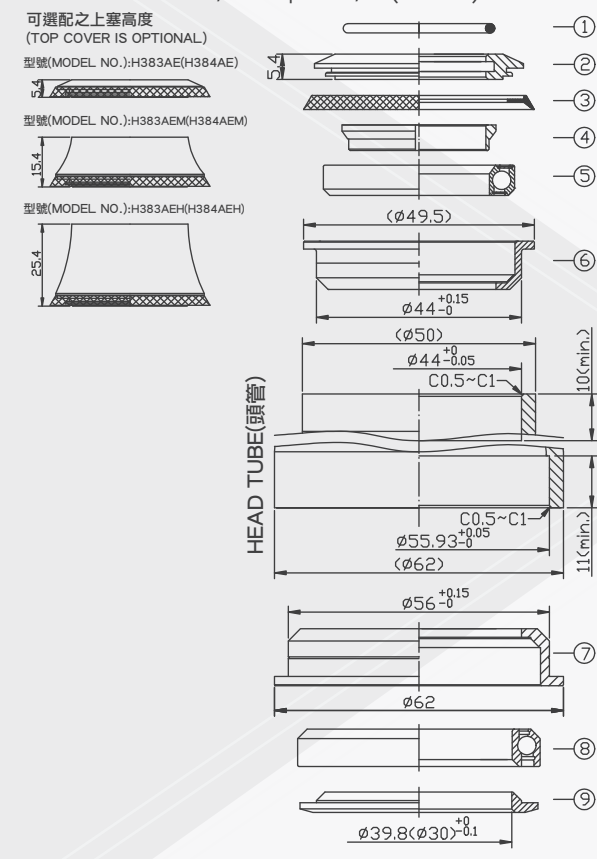

堆積高度(STACK HEIGHT)=9.5±1mm

NO.	零件名稱 PART NAME	材質 MATERIAL	圖號 DRAWING NO.	台量 QTY	尺寸 DIM. DESCRIPTION
1	O形圈 O-Ring	橡膠 NBR	120-8	1	ID28.5xØ2
2	上塞 TOP COVER	鋁合金 6061/T6	125-3	1	1-1/8"
3	防塵蓋 DUST-RESISTANT COVER	塑膠 NYLON	118-0	1	
4	鋁斜管 COMPRESSION RING	鋁合金 6061/T6	773-2	1	1-1/8"
5	密封式軸承 A.C. SEALED BEARING	軸承鋼 SUJ2	NHB-5D	1	OD41 x 36" x45"
6	上碗 UPPER CUP	鋁合金 6061/T6	146-4/5	1	Ø44 ^{+0.15} / ₋₀
7	下碗 LOWER CUP	鋁合金 6061/T6	385E-5	1	Ø56 ^{+0.15} / ₀
8	特大密封式軸承 OVERSIZE A.C. SEALED BEARING	軸承鋼 SUJ2	NHB-15	1	OD52 x 45" x45"
9	下塞 CROWN RACE	鋁合金 7075/T6	151-6 (153-6)	1	Ø39.8(Ø30) ^{+0.1} / _{-0.1}

H385 H386 [H385E] [H386E]

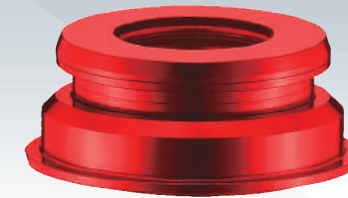

WEIGHT 97g
 SIZE 1.5" Head Tube Reduced to 1-1/8"
 Fork Tube Semi-Integrated Headset
 SHIS NORM ZS44/28.6 | ZS55/39.8 (H385)
 OPTIONAL ZS44/28.6 | ZS55/30(H386)
 OPTIONAL H385E/H386E:Lower Head Tube
 ID/OD.=56/62mm

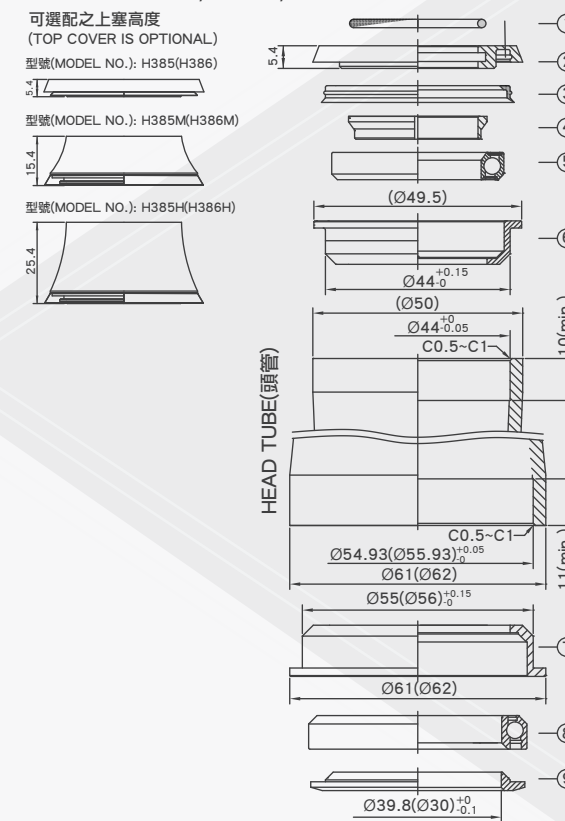

堆積高度(STACK HEIGHT)=9.5±1mm

NO.	零件名稱 PART NAME	材質 MATERIAL	圖號 DRAWING NO.	台量 QTY	尺寸 DIM. DESCRIPTION
1	O形圈 O-Ring	橡膠 NBR	120-8	1	ID28.5xØ2
2	上塞 TOP COVER	鋁合金 6061/T6	385-3	1	1-1/8"
3	防塵蓋 DUST-RESISTANT COVER	橡膠 NBR	273-0	1	
4	鋁斜管 COMPRESSION RING	鋁合金 6061/T6	773-2	1	1-1/8"
5	密封式軸承 A.C. SEALED BEARING	軸承鋼 SUJ2	NHB-5D	1	OD41 x 36" x45"
6	鋁上碗 UPPER CUP	鋁合金 6061/T6	146-4/5	1	Ø44 ^{+0.15} / ₋₀
7	鋁下碗 LOWER CUP	鋁合金 6061/T6	385-5 (385E-5)	1	Ø55(Ø56) ^{+0.15} / ₀
8	特大密封式軸承 OVERSIZE A.C. SEALED BEARING	軸承鋼 SUJ2	NHB-15	1	OD52 x 45" x45"
9	鋁下塞 CROWN RACE	鋁合金 7075/T6	151-6 (153-6)	1	Ø39.8(Ø30) ^{+0.1} / _{-0.1}

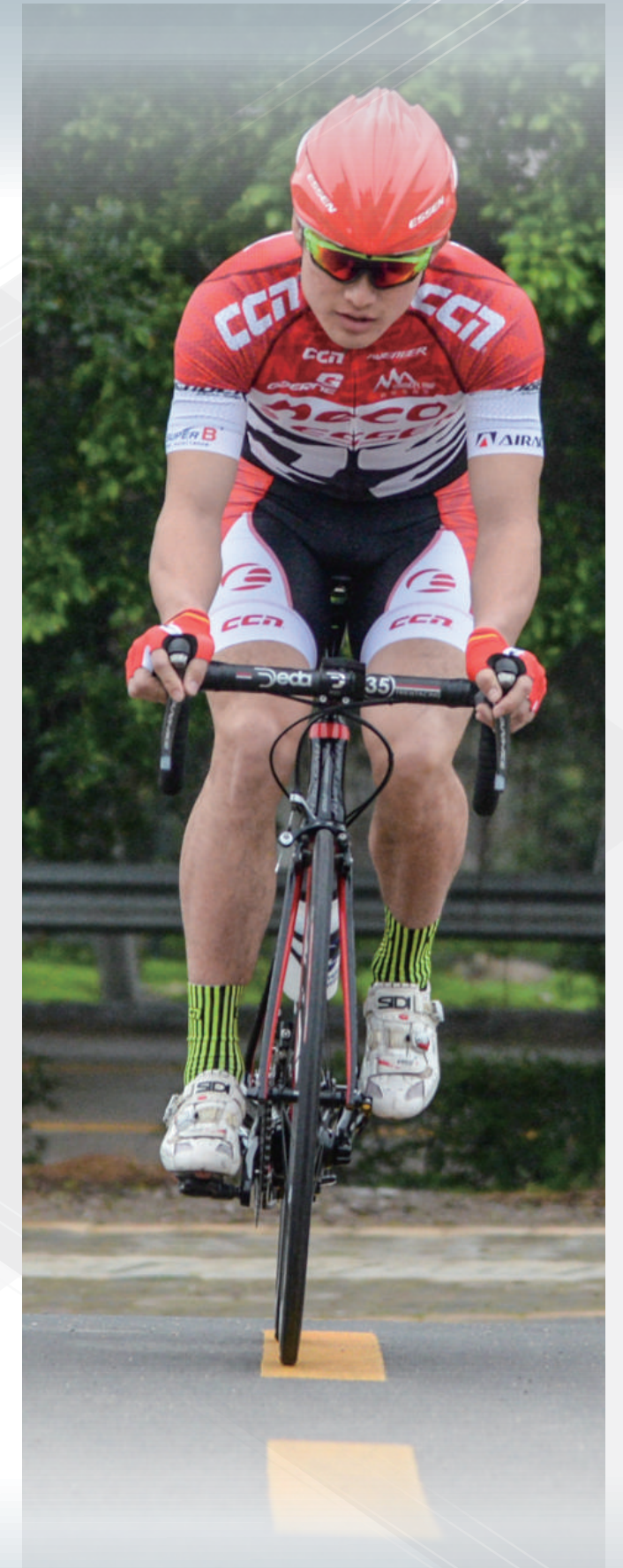

SEMI-INTEGRATED THREADED HEADSETS

H108 [H108H]



WEIGHT 106g
 SIZE 1" Semi-Integrated Threaded Headset
 DIMENSIONS $\varnothing 22.4 \times 44 / 50 \times 27 (26.4)$

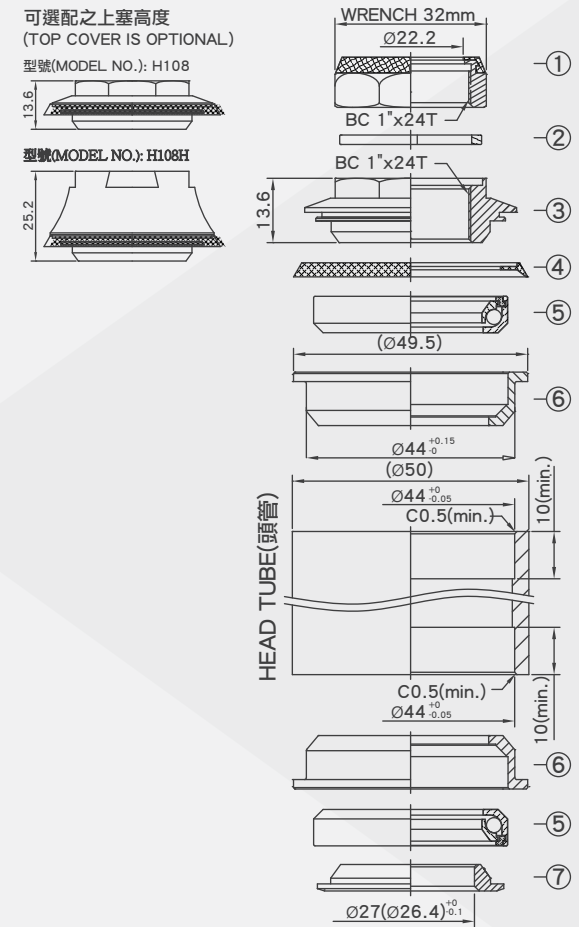

堆積高度(STACK HEIGHT)=23.2 ± 1mm

NO.	零件名稱 PART NAME	材質 MATERIAL	圖號 DRAWING NO.	台量 QTY	尺寸 DIM. DESCRIPTION
1	鋁防水上迫緊 LOCK NUT	鋁合金 6061/T6	807-1	1	BC 1"x24T
2	有領華司 KEY WASHER	碳鋼 STEEL	SK3002	1	1"
3	鋁上塞 ADJUSTING CONE	鋁合金 6061/T6	108-3	1	BC 1"x24T
4	防塵蓋 DUST-RESISTANT COVER	塑膠 NYLON	118-8	1	
5	卡式軸承 CARTRIDGE BALL BEARING	鉻鉬鋼 CR-MO STEEL	CBB-41	2	OD41 × 36 × 45°
6	鋁碗 CUPS	鋁合金 6061/T6	125-4/5	2	$\varnothing 44^{+0.15}_0$
7	下塞 CROWN RACE	碳鋼 STEEL	124-6	1	$\varnothing 27(\varnothing 26.4)^{+0.1}_0$

H112N



WEIGHT 171g
 SIZE 1-1/8" Semi-Integrated Threaded Headset
 w/Alloy Cover
 DIMENSIONS $\varnothing 25.4 \times 44 / 50 \times 30$

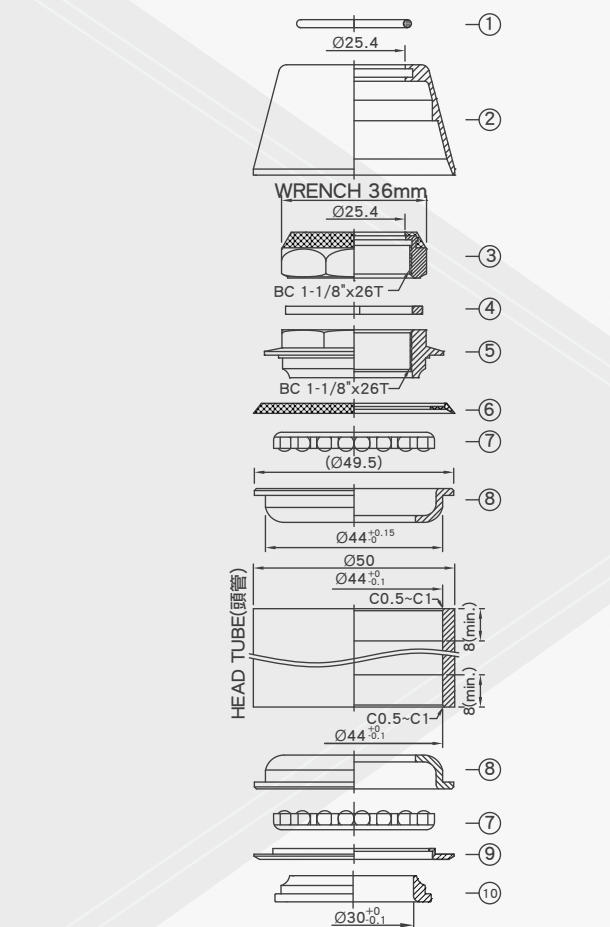

堆積高度(STACK HEIGHT)= 25.5 ± 1mm

NO.	零件名稱 PART NAME	材質 MATERIAL	圖號 DRAWING NO.	台量 QTY	尺寸 DIM. DESCRIPTION
1	O形圈 O-Ring	橡膠 NBR	121-8	1	ID25.3x $\varnothing 2$
2	鋁蓋 TOP COVER	鋁合金 6061/T6	112-0	1	1-1/8"
3	防水上迫緊 LOCK NUT	碳鋼 STEEL	841SW-1	1	BC 1-1/8"x26T
4	有領華司 KEY WASHER	碳鋼 STEEL	SK3402	1	1-1/8"
5	上塞 ADJUSTING CONE	碳鋼 STEEL	128-3	1	BC 1-1/8"x26T
6	防塵蓋 DUST-RESISTANT COVER	塑膠 NYLON	118-8	1	
7	珠巢 BALL RETAINER	碳鋼 STEEL		2	5/32"x22
8	上下碗 CUPS	碳鋼 STEEL	142-4/5	2	$\varnothing 44^{+0.15}_0$
9	塑膠防塵蓋 DUST-RESISTANT COVER	塑膠 NYLON	115-2A	1	
10	下塞 CROWN RACE	碳鋼 STEEL	841-6	1	$\varnothing 30^{+0.1}_0$

H113N



WEIGHT 163g
 SIZE 1-1/8" Semi-Integrated Threaded Headset
 w/Plastic Cover
 DIMENSIONS $\varnothing 25.4 \times 44 / 50 \times 30$

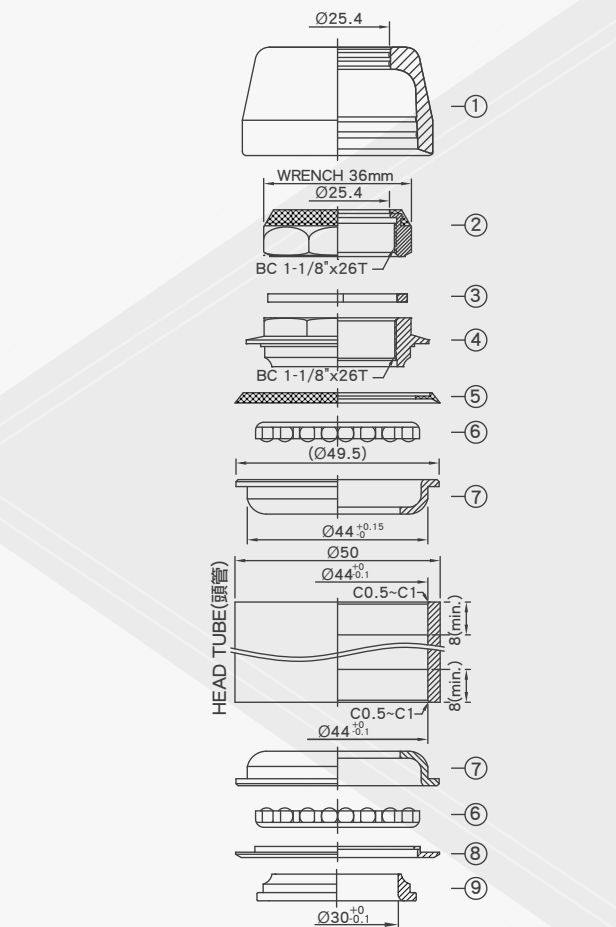

堆積高度(STACK HEIGHT)=25.5 ± 1mm

NO.	零件名稱 PART NAME	材質 MATERIAL	圖號 DRAWING NO.	台量 QTY	尺寸 DIM. DESCRIPTION
1	塑膠蓋 TOP COVER	塑膠 NYLON	113-0	1	1-1/8"
2	防水上迫緊 LOCK NUT	碳鋼 STEEL	841SW-1	1	BC 1-1/8"x26T
3	有領華司 KEY WASHER	碳鋼 STEEL	SK3402	1	1-1/8"
4	上塞 ADJUSTING CONE	碳鋼 STEEL	128-3	1	BC 1-1/8"x26T
5	防塵蓋 DUST-RESISTANT COVER	塑膠 NYLON	118-8	1	
6	珠巢 BALL RETAINER	碳鋼 STEEL		2	5/32"x22
7	上下碗 CUPS	碳鋼 STEEL	142-4/5	2	$\varnothing 44^{+0.15}_0$
8	塑膠防塵蓋 DUST-RESISTANT COVER	塑膠 NYLON	115-2A	1	
9	下塞 CROWN RACE	碳鋼 STEEL	841-6	1	$\varnothing 30^{+0.1}_0$

H118 [H118H]



WEIGHT 103g
 SIZE 1-1/8" Semi-Integrated Threaded Headset
 DIMENSIONS $\varnothing 25.4 \times 44 / 50 \times 30$

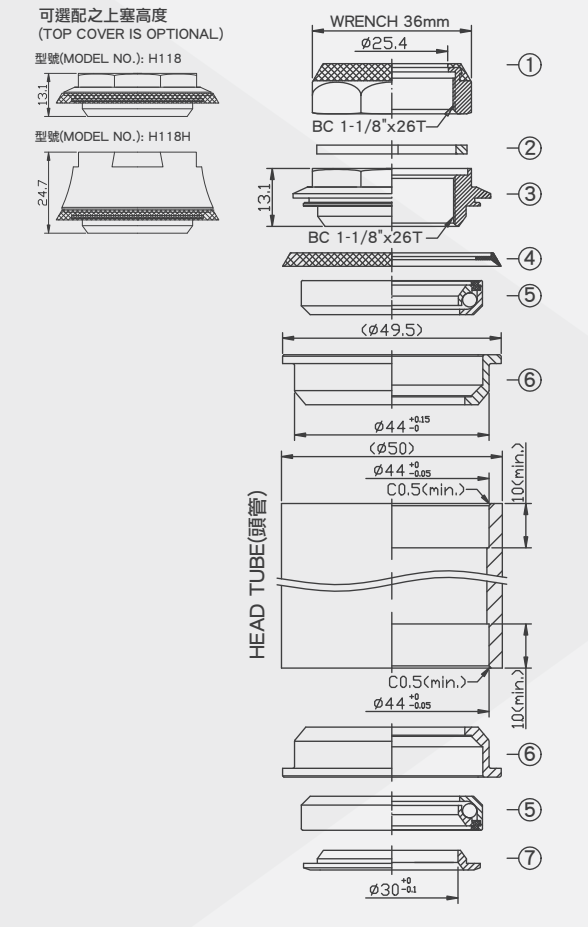

堆積高度(STACK HEIGHT)=23.5 ± 1mm

NO.	零件名稱 PART NAME	材質 MATERIAL	圖號 DRAWING NO.	台量 QTY	尺寸 DIM. DESCRIPTION
1	鋁防水上迫緊 LOCK NUT	鋁合金 6061/T6	815-1	1	BC 1-1/8"x26T
2	有領華司 KEY WASHER	碳鋼 STEEL	SK3402	1	1-1/8"
3	鋁上塞 ADJUSTING CONE	鋁合金 6061/T6	118-3	1	BC 1-1/8"x26T
4	防塵蓋 DUST-RESISTANT COVER	塑膠 NYLON	118-8	1	
5	卡式軸承 CARTRIDGE BALL BEARING	鉻鉬鋼 CR-MO STEEL	CBB-41	2	OD41 × 36 × 45°
6	鋁碗 CUPS	鋁合金 6061/T6	125-4/5	2	$\varnothing 44^{+0.15}_0$
7	下塞 CROWN RACE	碳鋼 STEEL	146-6	1	$\varnothing 30^{+0.1}_0$

SEMI-INTEGRATED THREADED HEADSETS

SEMI-INTEGRATED THREADED HEADSETS

SEMI-INTEGRATED THREADED HEADSETS

H127



WEIGHT 128g
 SIZE 1" Semi-Integrated Threaded Headset
 DIMENSIONS $\varnothing 22.2 \times 41.4 / 46 \times 27 (26.4)$

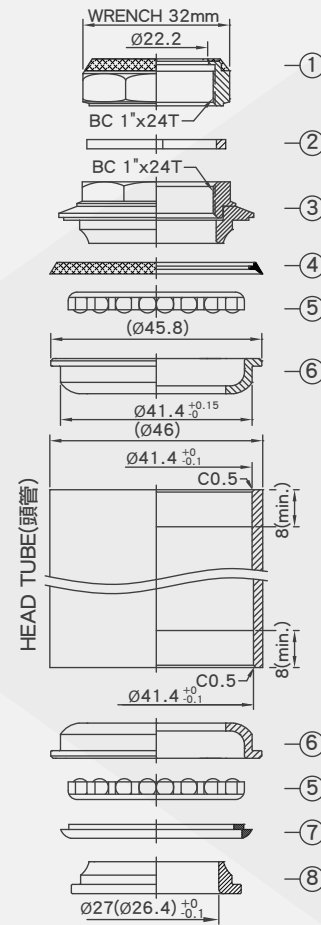

堆積高度(STACK HEIGHT)=25.2±1mm

NO.	零件名稱 PART NAME	材質 MATERIAL	圖號 DRAWING NO.	台量 Q' TY	尺寸 DIM. DESCRIPTION
1	防水上迫緊 LOCK NUT	碳鋼 STEEL	831SW-1	1	BC 1"x24T
2	有領華司 KEY WASHER	碳鋼 STEEL	SK3002	1	1"
3	上塞 ADJUSTING CONE	碳鋼 STEEL	127-3	1	BC 1"x24T
4	防塵蓋 DUST-RESISTANT COVER	塑膠 NYLON	141-8	1	
5	珠巢 BALL RETAINER	碳鋼 STEEL		2	5/32"x16
6	上下碗 CUPS	碳鋼 STEEL	141-4/5	2	$\varnothing 41.4^{+0.15}_0$
7	下防水圈 LOWER DUST RESISTANT COVER	塑膠 NYLON	831SW-8	1	
8	下塞 CROWN RACE	碳鋼 STEEL	800-6	1	$\varnothing 27(\varnothing 26.4)^{+0.1}_0$

H128N



WEIGHT 153g
 SIZE 1-1/8" Semi-Integrated Threaded Headset
 DIMENSIONS $\varnothing 25.4 \times 44 / 50 \times 30$

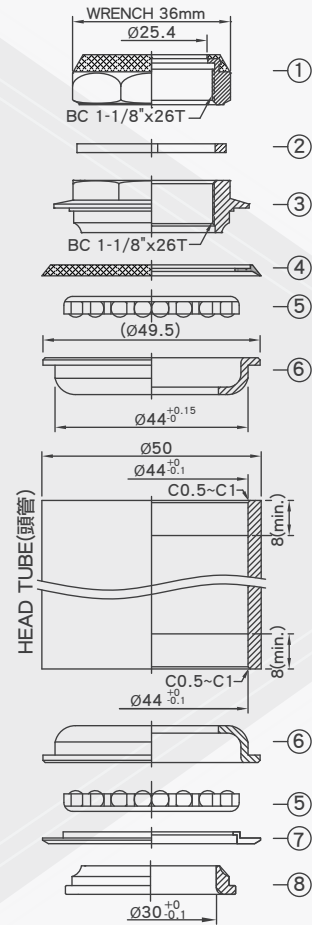

堆積高度(STACK HEIGHT)=25.5±1mm

NO.	零件名稱 PART NAME	材質 MATERIAL	圖號 DRAWING NO.	台量 Q' TY	尺寸 DIM. DESCRIPTION
1	防水上迫緊 LOCK NUT	碳鋼 STEEL	841SW-1	1	BC 1-1/8"x26T
2	有領華司 KEY WASHER	碳鋼 STEEL	SK3402	1	1-1/8"
3	上塞 ADJUSTING CONE	碳鋼 STEEL	128-3	1	BC 1-1/8"x26T
4	防塵蓋 DUST-RESISTANT COVER	塑膠 NYLON	118-8	1	
5	珠巢 BALL RETAINER	碳鋼 STEEL		1	5/32"x22
6	上下碗 CUPS	碳鋼 STEEL	142-4/5	1	$\varnothing 44^{+0.15}_0$
7	塑膠防塵蓋 DUST-RESISTANT COVER	塑膠 NYLON	115-2A	1	
8	下塞 CROWN RACE	碳鋼 STEEL	841-6	1	$\varnothing 30^{+0.1}_0$

H129



WEIGHT 155g
 SIZE 1-1/8" Semi-Integrated Threaded Headset
 DIMENSIONS $\varnothing 25.4 \times 44 / 50 \times 30$

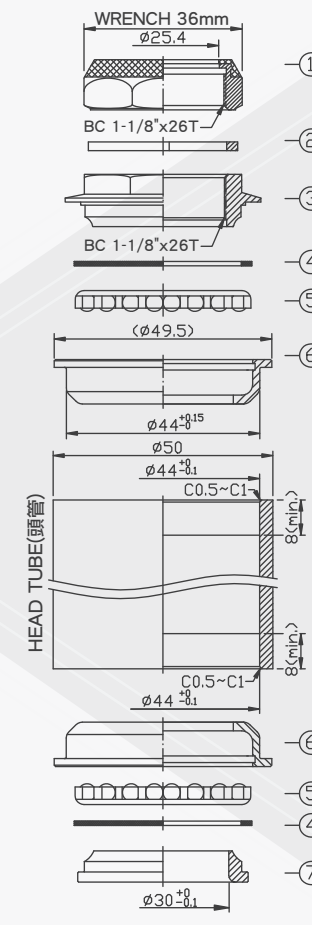

堆積高度(STACK HEIGHT)=22.4±1mm

NO.	零件名稱 PART NAME	材質 MATERIAL	圖號 DRAWING NO.	台量 Q' TY	尺寸 DIM. DESCRIPTION
1	防水上迫緊 LOCK NUT	碳鋼 STEEL	841SW-1	1	BC 1-1/8"x26T
2	有領華司 KEY WASHER	碳鋼 STEEL	SK3402	1	1-1/8"
3	上塞 ADJUSTING CONE	碳鋼 STEEL	128-3	1	BC 1-1/8"x26T
4	防水圈 RUBBER SEAL	橡膠 RUBBER	841SW-9	2	
5	珠巢 BALL RETAINER	碳鋼 STEEL		2	5/32"x22
6	上下碗 CUPS	碳鋼 STEEL	148-4/5-1 (129-4/5)	2	$\varnothing 44^{+0.15}_0$
7	下塞 CROWN RACE	碳鋼 STEEL	841-6	1	$\varnothing 30^{+0.1}_0$

H161L [H161H]



WEIGHT 161L: 127g, 161H: 150g
 SIZE 1" Semi-Integrated Threaded Headset
 DIMENSIONS $\varnothing 22.2 \times 44 / 50 \times 27 (26.4)$

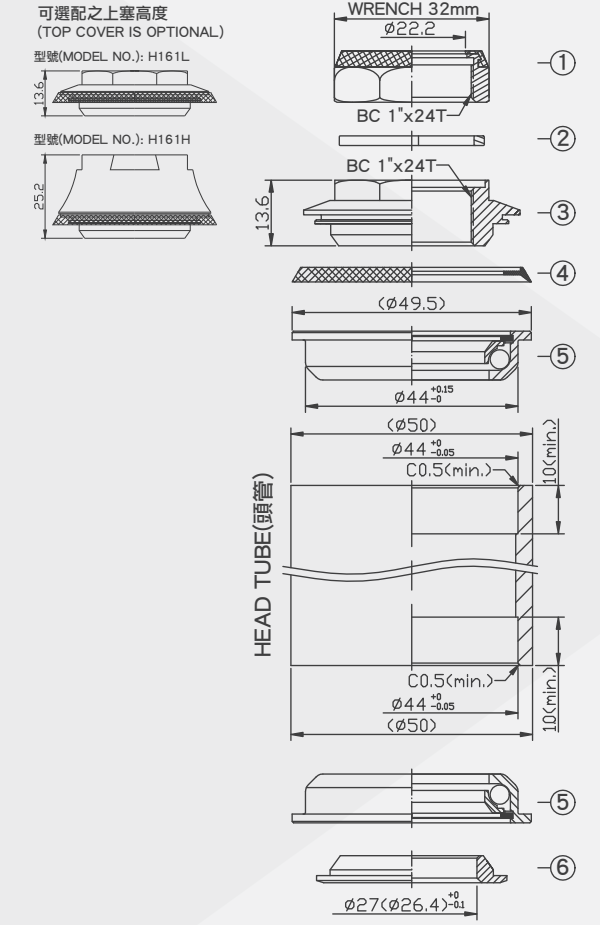

堆積高度(STACK HEIGHT)=23.7±1mm

NO.	零件名稱 PART NAME	材質 MATERIAL	圖號 DRAWING NO.	台量 Q' TY	尺寸 DIM. DESCRIPTION
1	防水上迫緊 LOCK NUT	鋁合金 6061/T6	807-1	1	BC 1"x24T
2	有領華司 KEY WASHER	碳鋼 STEEL	SK3002	1	1"
3	鋁上塞 ADJUSTING CONE	鋁合金 6061/T6	108-3	1	BC 1"x24T
4	防塵蓋 DUST-RESISTANT COVER	塑膠 NYLON	118-8	1	
5	半卡式碗 SEMI-CARTRIDGE STEEL CUPS	碳鋼 STEEL	148-4/5	2	$\varnothing 44^{+0.15}_0$
6	下塞 CROWN RACE	碳鋼 STEEL	124-6	1	$\varnothing 27(\varnothing 26.4)^{+0.1}_0$

H168



WEIGHT 100g
 SIZE 1-1/8" Semi-Integrated Threaded Headset
 DIMENSIONS $\varnothing 25.4 \times 44/50 \times 30$

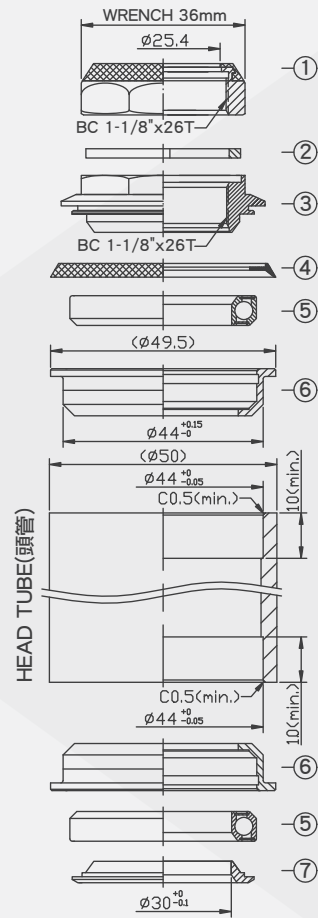

堆積高度(STACK HEIGHT)= 23.6 ± 1 mm

NO.	零件名稱 PART NAME	材質 MATERIAL	圖號 DRAWING NO.	台量 Q' TY	尺寸 DIM. DESCRIPTION
1	防水上迫緊 LOCK NUT	鋁合金 6061/T6	815-1	1	BC 1-1/8"x26T
2	有領華司 KEY WASHER	碳鋼 STEEL	SK3402	1	1-1/8"
3	鋁上塞 ADJUSTING CONE	鋁合金 6061/T6	168-3	1	BC 1-1/8"x26T
4	防塵蓋 DUST-RESISTANT COVER	塑膠 NYLON	118-8	1	
5	密封式軸承 A.C. SEALED BEARING	軸承鋼 SUJ2	NHB-5D	2	OD41x36"x45°
6	鋁碗 CUPS	鋁合金 6061/T6	146-4/5	2	$\varnothing 44^{+0.15}_{-0}$
7	鋁下塞 CROWN RACE	鋁合金 7075/T6	123-6	1	$\varnothing 30^{+0}_{-0.1}$

H171L [H171H]



WEIGHT H171L: 136g, H171H: 151g
 SIZE 1-1/8" Semi-Integrated Threaded Headset
 DIMENSIONS $\varnothing 25.4 \times 44/50 \times 30$

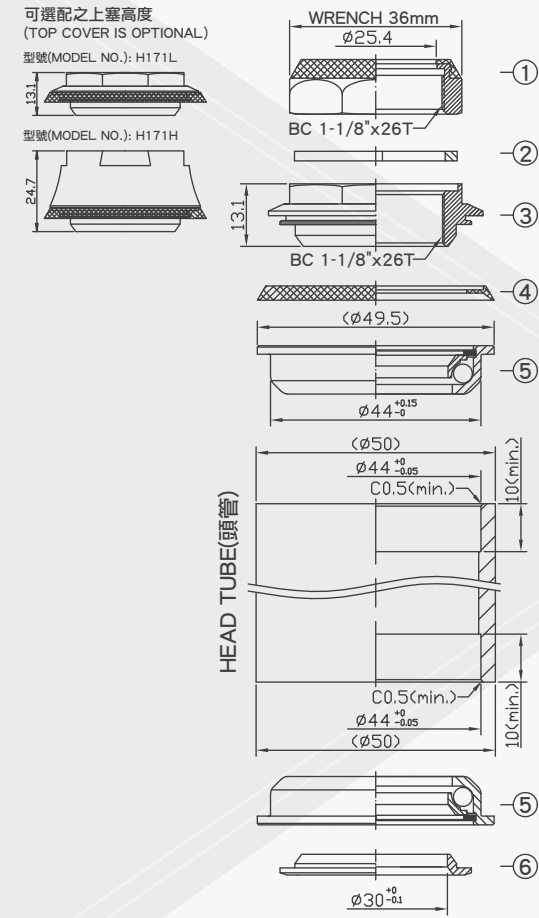

堆積高度(STACK HEIGHT)= 23.7 ± 1 mm

NO.	零件名稱 PART NAME	材質 MATERIAL	圖號 DRAWING NO.	台量 Q' TY	尺寸 DIM. DESCRIPTION
1	防水上迫緊 LOCK NUT	鋁合金 6061/T6	815-1	1	BC 1-1/8"x26T
2	有領華司 KEY WASHER	碳鋼 STEEL	SK3402	1	1-1/8"
3	鋁上塞 ADJUSTING CONE	鋁合金 6061/T6	118-3	1	BC 1-1/8"x26T
4	防塵蓋 DUST-RESISTANT COVER	塑膠 NYLON	118-8	1	
5	半卡式碗 SEMI-CARTRIDGE STEEL CUPS	碳鋼 STEEL	148-4/5	2	$\varnothing 44^{+0.15}_{-0}$
6	下塞 CROWN RACE	碳鋼 STEEL	146-6	1	$\varnothing 30^{+0}_{-0.1}$

H175



WEIGHT 159g
 SIZE 1-1/8" Semi-Integrated Threaded Headset
 DIMENSIONS $\varnothing 25.4 \times 44/50 \times 30$

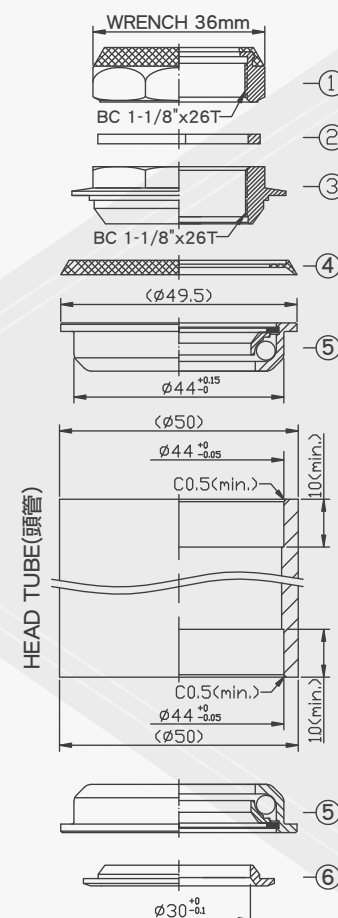

堆積高度(STACK HEIGHT)= 24.2 ± 1 mm

NO.	零件名稱 PART NAME	材質 MATERIAL	圖號 DRAWING NO.	台量 Q' TY	尺寸 DIM. DESCRIPTION
1	防水上迫緊 LOCK NUT	碳鋼 STEEL	841SW-1	1	BC 1-1/8"x26T
2	有領華司 KEY WASHER	碳鋼 STEEL	SK3402	1	1-1/8"
3	上塞 ADJUSTING CONE	碳鋼 STEEL	175-3	1	BC 1-1/8"x26T
4	防塵蓋 DUST-RESISTANT COVER	塑膠 NYLON	118-8	1	
5	半卡式碗 SEMI-CARTRIDGE STEEL CUPS	碳鋼 STEEL	148-4/5	2	$\varnothing 44^{+0.15}_{-0}$
6	下塞 CROWN RACE	碳鋼 STEEL	146-6	1	$\varnothing 30^{+0}_{-0.1}$

H184

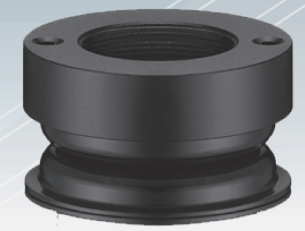

WEIGHT 130g
 SIZE 1-1/8" Semi-Integrated Threaded Headset
 DIMENSIONS $\varnothing 28.6 \times 44/50 \times 30$

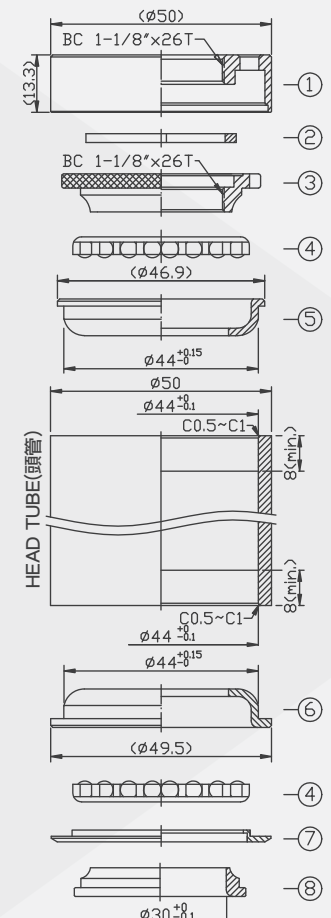

堆積高度(STACK HEIGHT)= 18 ± 1 mm

NO.	零件名稱 PART NAME	材質 MATERIAL	圖號 DRAWING NO.	台量 Q' TY	尺寸 DIM. DESCRIPTION
1	鋁上迫緊 LOCK NUT	鋁合金 6061/T6	184-1	1	BC 1-1/8"x26T
2	有領華司 KEY WASHER	碳鋼 STEEL	SK3402	1	1-1/8"
3	上塞 ADJUSTING CONE	碳鋼 STEEL	184-3	1	BC 1-1/8"x26T
4	珠巢 BALL RETAINER	碳鋼 STEEL		2	5/32"x22
5	上碗 UPPER CUP	碳鋼 STEEL	184-4	1	$\varnothing 44^{+0.15}_{-0}$
6	下碗 LOWER CUP	碳鋼 STEEL	142-4/5	1	$\varnothing 44^{+0.15}_{-0}$
7	塑膠防塵蓋 DUST-RESISTANT COVER	塑膠 NYLON	115-2A	1	
8	下塞 CROWN RACE	碳鋼 STEEL	841-6	1	$\varnothing 30^{+0}_{-0.1}$

H186

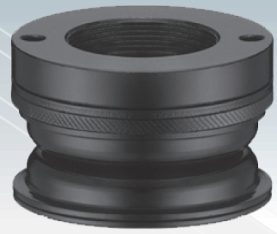

WEIGHT 130g
 SIZE 1-1/8" Semi-Integrated Threaded Headset
 DIMENSIONS Ø25.4x44/50x30

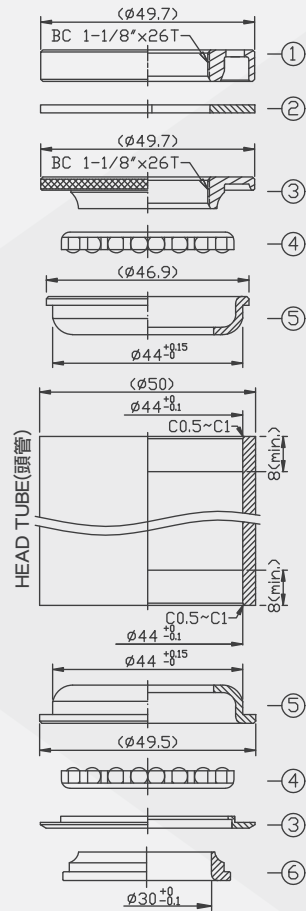

堆積高度(STACK HEIGHT)=17.7±1mm

NO.	零件名稱 PART NAME	材質 MATERIAL	圖號 DRAWING NO.	台量 QTY	尺寸 DIM. DESCRIPTION
1	上迫緊 LOCK NUT	碳鋼 STEEL	842-2-1	1	BC 1-1/8"x26T
2	有領華司 KEY WASHER	碳鋼 STEEL	842-2-2	1	2xOD49.6
3	上塞 ADJUSTING CONE	碳鋼 STEEL	186-3	1	BC 1-1/8"x26T
4	珠巢 BALL RETAINER	碳鋼 STEEL		2	5/32"x22
5	上碗 UPPER CUP	碳鋼 STEEL	184-4	1	Ø44 ^{+0.15} ₋₀
6	下碗 LOWER CUP	碳鋼 STEEL	142-4/5	1	Ø44 ^{+0.15} ₋₀
7	塑膠防塵蓋 DUST-RESISTANT COVER	塑膠 NYLON	115-2A	1	
8	下塞 CROWN RACE	碳鋼 STEEL	841-6	1	Ø30 ⁺⁰ _{-0.1}

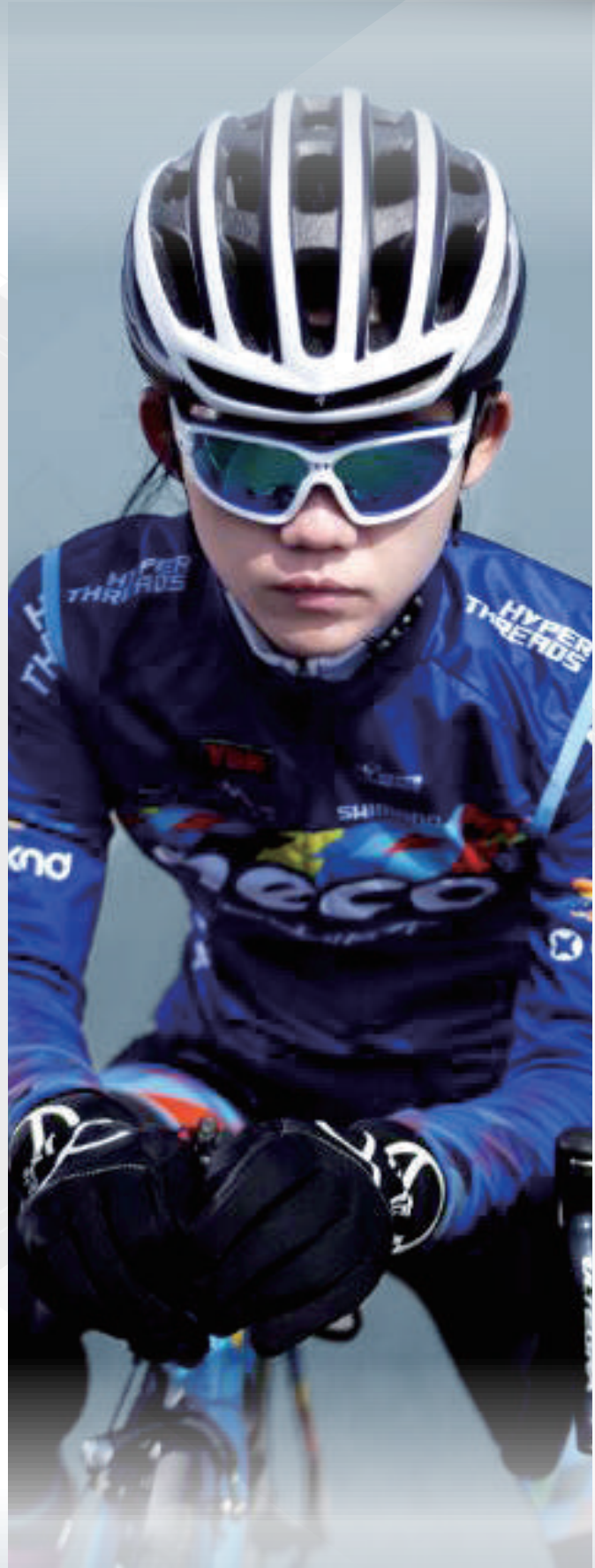

H151BW



1.5" OVERSIZE HEADSET SEALED BEARING LIGHT ALLOY
 WEIGHT 175.5g
 SIZE 1-1/2" Threadless Headset
 SHIS NORM EC49.7/38.1 | EC49.7/39.8

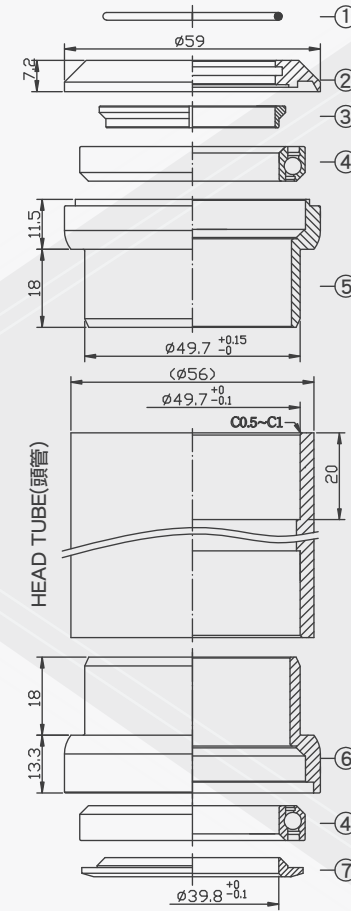

堆積高度(STACK HEIGHT)=32±1mm

NO.	零件名稱 PART NAME	材質 MATERIAL	圖號 DRAWING NO.	台量 QTY	尺寸 DIM. DESCRIPTION
1	O形圈 O-Ring	橡膠 NBR	151-8	1	ID37.82xØ1.78
2	鋁上塞 TOP COVER	鋁合金 6061/T6	151-3	1	1.5"
3	鋁斜管 COMPRESSION RING	鋁合金 6061/T6	151-2	1	1.5"
4	特大型密封式軸承 OVERSIZE A.C. SEALED BEARING	軸承鋼 SUJ2	NHB-15	2	OD52×45°x45°
5	上碗 UPPER CUP	鋁合金 6061/T6	151-4	1	Ø49.7 ^{+0.15} ₋₀
6	下碗 LOWER CUP	鋁合金 6061/T6	151-5	1	Ø49.7 ^{+0.15} ₋₀
7	鋁下塞 CROWN RACE	鋁合金 7075/T6	151-6	1	Ø39.8 ⁺⁰ _{-0.1}

H153BW



1.5" REDUCED TO 1-1/8" SEALED BEARING LIGHT ALLOY
 WEIGHT 194g
 SIZE 1-1/8" Threadless Headset
 SHIS NORM EC49.7/28.6 | EC49.7/39.8

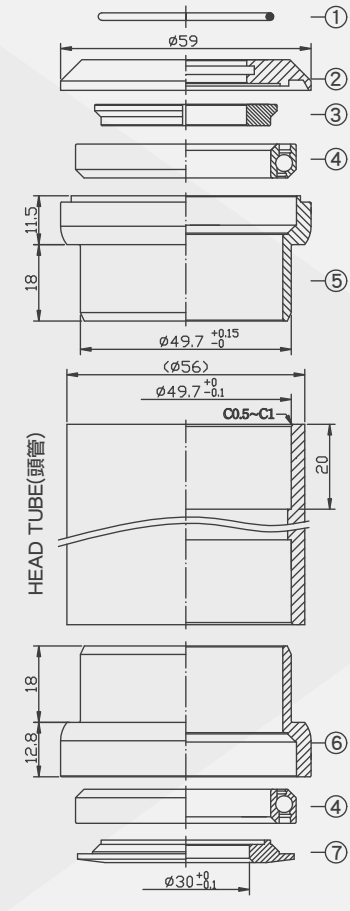

堆積高度(STACK HEIGHT)=32±1mm

NO.	零件名稱 PART NAME	材質 MATERIAL	圖號 DRAWING NO.	台量 QTY	尺寸 DIM. DESCRIPTION
1	O形圈 O-Ring	橡膠 NBR	120-8	1	ID28.5xØ2
2	鋁上塞 TOP COVER	鋁合金 6061/T6	153-3	1	1-1/8"
3	鋁斜管 COMPRESSION RING	鋁合金 6061/T6	153-2	1	1-1/8"
4	特大型密封式軸承 OVERSIZE A.C. SEALED BEARING	軸承鋼 SUJ2	NHB-15	2	OD52×45°x45°
5	上碗 UPPER CUP	鋁合金 6061/T6	151-4	1	Ø49.7 ^{+0.15} ₋₀
6	下碗 LOWER CUP	鋁合金 6061/T6	151-5	1	Ø49.7 ^{+0.15} ₋₀
7	鋁下塞 CROWN RACE	鋁合金 7075/T6	153-6	1	Ø30 ⁺⁰ _{-0.1}

外露式無牙車頭碗
EXTERNAL CUP THREADLESS HEADSETS

外露式無牙車頭碗
EXTERNAL CUP THREADLESS HEADSETS

H252



WEIGHT 98.6g
SIZE 1" Threadless Headset
SHIS NORM EC30/25.4 | EC30/27(26.4)

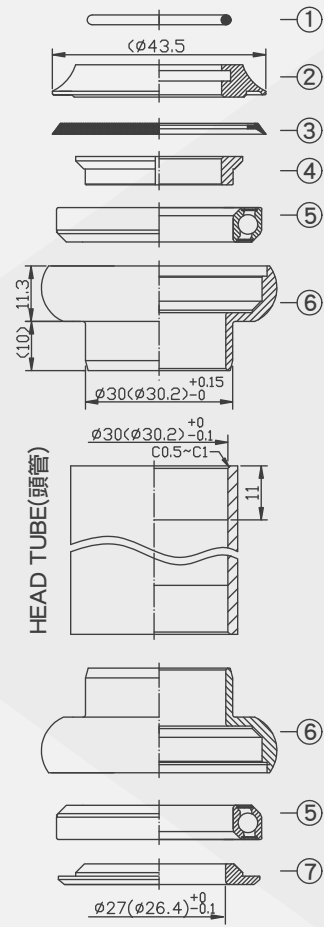

堆積高度(STACK HEIGHT)=29 ± 1mm

NO.	零件名稱 PART NAME	材質 MATERIAL	圖號 DRAWING NO.	台量 Q' TY	尺寸 DIM. DESCRIPTION
1	O形圈 O-Ring	橡膠 NBR	121-8	1	ID25.3xØ2
2	鋁上塞 TOP COVER	鋁合金 6061/T6	252-3	1	1"
3	防塵蓋 DUST-RESISTANT COVER	塑膠 NYLON	701-8	1	
4	鋁斜管 COMPRESSION RING	鋁合金 6061/T6	05-2	1	1"
5	密封式軸承 A.C. SEALED BEARING	軸承鋼 SUJ2	NHB-6B	2	OD41.8x45°x45°
6	碗 CUPS	鋁合金 6061/T6	252-4/5	2	Ø30(Ø30.2) ^{+0.15} ₀
7	鋁下塞 CROWN RACE	鋁合金 7075/T6	05-6	1	Ø27(Ø26.4) ⁺⁰ _{-0.1}

H282



OPTIONAL H2820

WEIGHT 95g
SIZE 1-1/8" Threadless Headset
SHIS NORM EC34/28.6 | 34/30
OPTIONAL H2820:EC34/28.6 | EC34/30 Height:27 ± 1mm

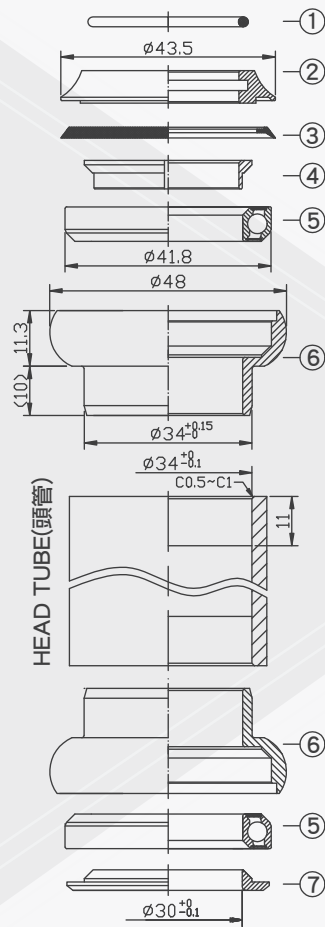

堆積高度(STACK HEIGHT)=29 ± 1mm

NO.	零件名稱 PART NAME	材質 MATERIAL	圖號 DRAWING NO.	台量 Q' TY	尺寸 DIM. DESCRIPTION
1	O形圈 O-Ring	橡膠 NBR	120-8	1	ID28.5xØ2
2	鋁上塞 TOP COVER	鋁合金 6061/T6	282-3	1	1-1/8"
3	防塵蓋 DUST-RESISTANT COVER	塑膠 NYLON	701-8	1	
4	鋁斜管 COMPRESSION RING	鋁合金 6061/T6	51-2	1	1-1/8"
5	密封式軸承 A.C. SEALED BEARING	軸承鋼 SUJ2	NHB-6B	2	OD41.8x45°x45°
6	碗 CUPS	鋁合金 6061/T6	282-4/5	2	Ø34 ^{+0.15} ₀
7	鋁下塞 CROWN RACE	鋁合金 7075/T6	51-6	1	Ø30 ⁺⁰ _{-0.1}

H370



WEIGHT 115g
SIZE 1-1/8" Threadless Headset
SHIS NORM EC34/28.6 | EC34/30

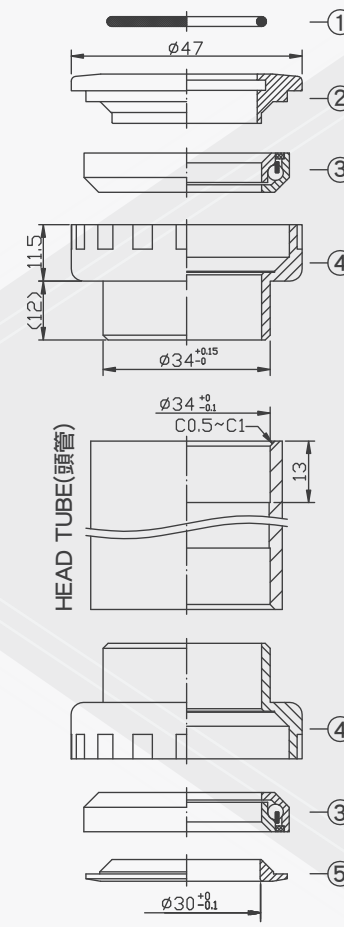

堆積高度(STACK HEIGHT)=28.3 ± 1mm

NO.	零件名稱 PART NAME	材質 MATERIAL	圖號 DRAWING NO.	台量 Q' TY	尺寸 DIM. DESCRIPTION
1	O形圈 O-Ring	橡膠 NBR	120-8	1	ID28.5xØ2
2	上塞 TOP COVER	鋁合金 7075/T6	370-3	1	1-1/8"
3	密封式軸承 A.C. SEALED BEARING	軸承鋼 SUJ2	NHB-6D	2	OD41.8x45°x45°
4	鋁碗 CUPS	鋁合金 7075/T6	370-4/5	2	Ø34 ^{+0.15} ₀
5	鋁下塞 CROWN RACE	鋁合金 7075/T6	370-6	1	Ø30 ⁺⁰ _{-0.1}

H610



WEIGHT 104g
SIZE 1" Threadless Headset
SHIS NORM EC30/25.4 | EC30/27(26.4)

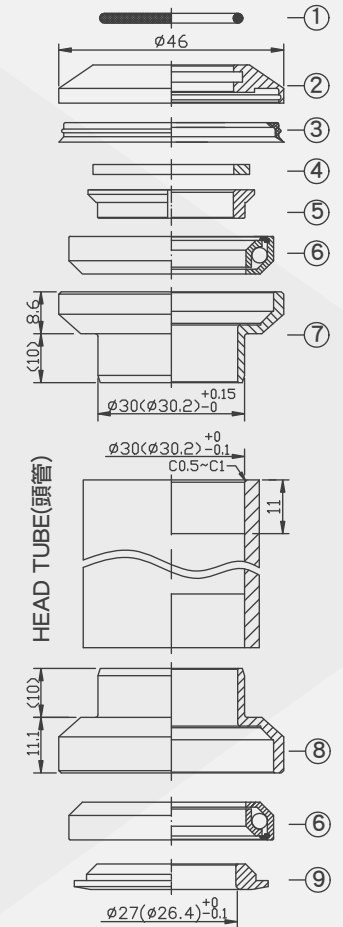

堆積高度(STACK HEIGHT)=29 ± 1mm

NO.	零件名稱 PART NAME	材質 MATERIAL	圖號 DRAWING NO.	台量 Q' TY	尺寸 DIM. DESCRIPTION
1	O形圈 O-Ring	橡膠 NBR	121-8	1	ID25.3xØ2
2	鋁上塞 TOP COVER	鋁合金 6061/T6	05-3	1	1"
3	防塵蓋 RUBBER SEAL	橡膠 NBR	273-0	1	
4	中圈華司 ALLOY SPACER	鋁合金 6061/T6	AS3202	1	2txOD32
5	鋁斜管 COMPRESSION RING	鋁合金 6061/T6	05-2	1	1"
6	卡式軸承 CARTRIDGE BALL BEARING	鉻鉬鋼 CR-MO	CBB-418	2	OD41.8x45°x45°
7	鋁上碗 UPPER CUP	鋁合金 6061/T6	610-4	1	Ø30(Ø30.2) ^{+0.15} ₀
8	鋁下碗 LOWER CUP	鋁合金 6061/T6	610-5	1	Ø30(Ø30.2) ^{+0.15} ₀
9	下塞 CROWN RACE	碳鋼 STEEL	671-6	1	Ø27(Ø26.4) ⁺⁰ _{-0.1}

外露式無牙車頭碗
EXTERNAL CUP THREADLESS HEADSETS

外露式無牙車頭碗
EXTERNAL CUP THREADLESS HEADSETS

H626



WEIGHT 103.1g
SIZE 1" Threadless Headset
SHIS NORM EC30/25.4 | EC30/27(26.4)

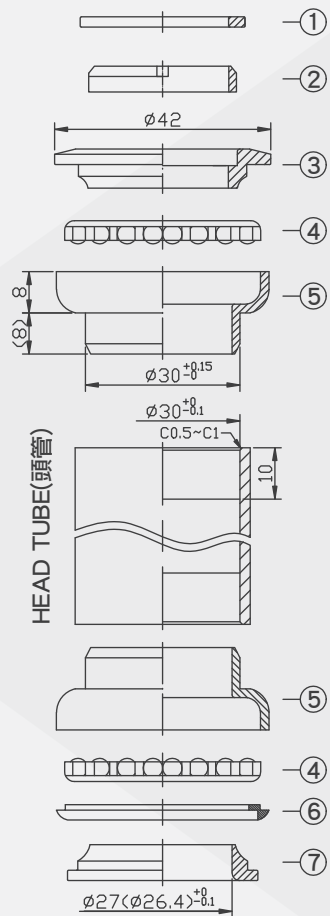

堆積高度(STACK HEIGHT)=24.5 ± 1mm

NO.	零件名稱 PART NAME	材質 MATERIAL	圖號 DRAWING NO.	台量 Q' TY	尺寸 DIM. DESCRIPTION
1	墊片 SPACER	碳鋼 STEEL	SD3202	1	2xOD32(1")
2	固定圈 COMPRESSING RING	橡膠 NBR	820-2	1	1"
3	上塞 TOP COVER	碳鋼 STEEL	626-3	1	1"
4	珠巢 BALL RETAINER	碳鋼 STEEL		2	5/32"x16
5	碗 CUPS	碳鋼 STEEL	820-5	2	Ø30 ^{+0.15} ₋₀
6	防水圈 DUST-RESISTANT COVER	塑膠 NYLON	831SW-8	1	
7	下塞 CROWN RACE	碳鋼 STEEL	800-6	1	Ø27(Ø26.4) ⁺⁰ _{-0.1}

H673



WEIGHT 92g
SIZE 1" Threadless Headset
SHIS NORM EC30/25.4 | EC30/27(26.4)

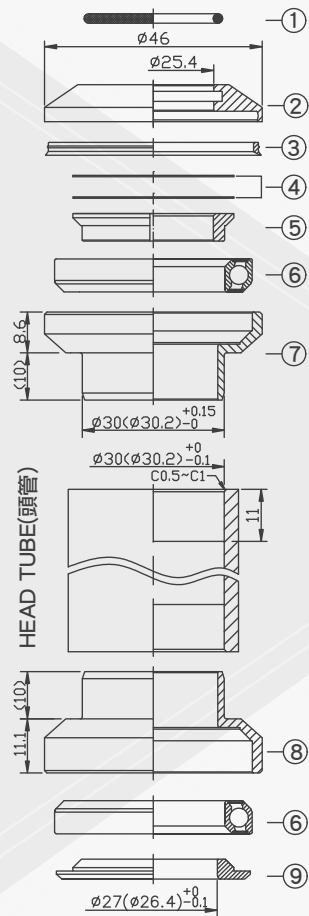

堆積高度(STACK HEIGHT)=29.5 ± 1mm

NO.	零件名稱 PART NAME	材質 MATERIAL	圖號 DRAWING NO.	台量 Q' TY	尺寸 DIM. DESCRIPTION
1	O形圈 O-Ring	橡膠 NBR	121-8	1	ID25.3xØ2
2	鋁上塞 TOP COVER	鋁合金 6061/T6	05-3	1	1"
3	防塵蓋 RUBBER SEAL	橡膠 NBR	273-0	1	
4	墊片 MICRO SPACER	不鏽鋼 SUS304		2	0.3t
5	鋁斜管 COMPRESSION RING	鋁合金 6061/T6	05-2	1	1"
6	密封式軸承 A.C. SEALED BEARING	軸承鋼 SUJ2	NHB-6B	2	OD41.8x45'x45'
7	鋁上碗 UPPER CUP	鋁合金 6061/T6	610-4	1	Ø30(Ø30.2) ^{+0.15} ₋₀
8	鋁下碗 LOWER CUP	鋁合金 6061/T6	610-5	1	Ø30(Ø30.2) ^{+0.15} ₋₀
9	鋁下塞 CROWN RACE	鋁合金 7075/T6	05-6	1	Ø27(Ø26.4) ⁺⁰ _{-0.1}

H701



Smart design that gives an integrated style-like look
WEIGHT 92g
SIZE 1-1/8" Threadless Headset
SHIS NORM EC34/28.6 | EC34/30

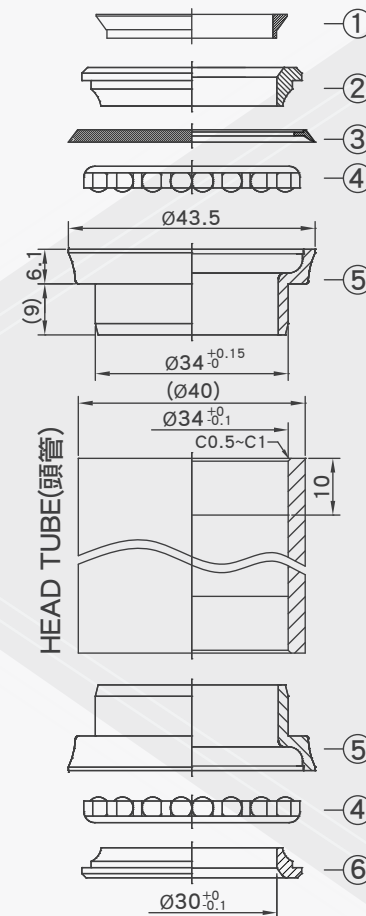

堆積高度(STACK HEIGHT)=20 ± 1mm

NO.	零件名稱 PART NAME	材質 MATERIAL	圖號 DRAWING NO.	台量 Q' TY	尺寸 DIM. DESCRIPTION
1	塑膠斜管 COMPRESSION RING	塑膠 NYLON	701-2	1	1-1/8"
2	上塞 TOP COVER	碳鋼 STEEL	701-3	1	1-1/8"
3	防塵蓋 DUST-RESISTANT COVER	塑膠 NYLON	701-8	1	
4	珠巢 BALL RETAINER	碳鋼 STEEL		2	1/8"x25
5	碗 CUPS	碳鋼 STEEL	701-4/5	2	Ø34 ^{+0.15} ₋₀
6	下塞 CROWN RACE	碳鋼 STEEL	701-6	1	Ø30 ⁺⁰ _{-0.1}

H706



WEIGHT 95g
SIZE 1-1/8" Threadless Headset
SHIS NORM EC34/28.6 | 34/30
OPTIONAL H706M EC34/28.6 | EC34/30 HEIGHT: 35.6 ± 1mm

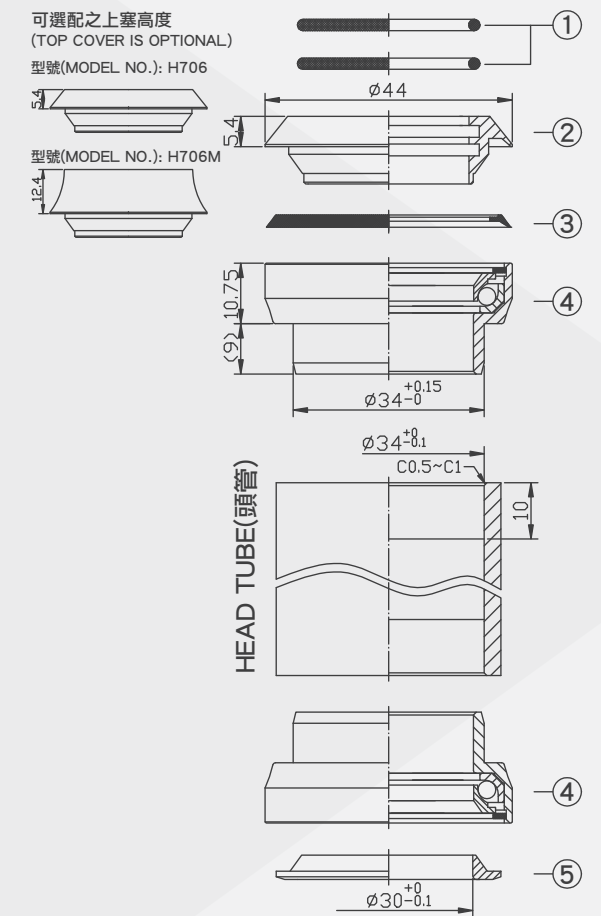

堆積高度(STACK HEIGHT)=28.6 ± 1mm

NO.	零件名稱 PART NAME	材質 MATERIAL	圖號 DRAWING NO.	台量 Q' TY	尺寸 DIM. DESCRIPTION
1	O形圈 O-Ring	橡膠 NBR	120-8	2	ID28.5xØ2
2	鋁上塞 TOP COVER	鋁合金 6061/T6	706-3	1	1-1/8"
3	防塵蓋 DUST-RESISTANT COVER	塑膠 NYLON	701-8	1	
4	鋁卡式碗 CARTRIDGE ALLOY CUP	鋁合金 6061/T6	706-4/5	2	Ø34 ^{+0.15} ₋₀
5	下塞 CROWN RACE	碳鋼 STEEL	146-6	1	Ø30 ⁺⁰ _{-0.1}

H711



WEIGHT 112g
SIZE 1-1/8" Threadless Headset
SHIS NORM EC34/28.6 | EC34/30

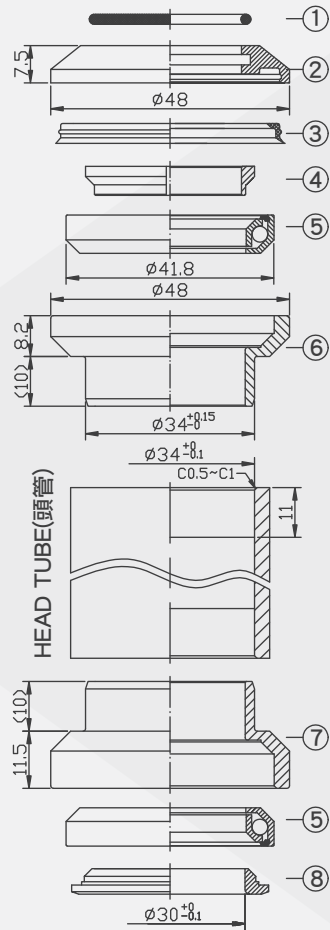

堆積高度(STACK HEIGHT)=29 ± 1mm

NO.	零件名稱 PART NAME	材質 MATERIAL	圖號 DRAWING NO.	台量 Q' TY	尺寸 DIM. DESCRIPTION
1	O形圈 O-Ring	橡膠 NBR	120-8	1	ID28.5xØ2
2	鋁上塞 TOP COVER	鋁合金 6061/T6	773-3	1	1-1/8"
3	防塵蓋 RUBBER SEAL	橡膠 NBR	273-0	1	
4	鋁斜管 COMPRESSION RING	鋁合金 6061/T6	52-2	1	1-1/8"
5	卡式軸承 CARTRIDGE BALL BEARING	鉻鉬鋼 CR-MO STEEL	CBB-418	2	OD41.8 x 45° x 45°
6	上碗 UPPER CUP	鋁合金 6061/T6	773-4	1	Ø34 ^{+0.15} ₋₀
7	下碗 LOWER CUP	鋁合金 6061/T6	773-5	1	Ø34 ^{+0.15} ₋₀
8	下塞 CROWN RACE	碳鋼 STEEL	52-6	1	Ø30 ⁺⁰ _{-0.1}

H773



WEIGHT 102g
SIZE 1-1/8" Threadless Headset
SHIS NORM EC34/28.6 | EC34/30

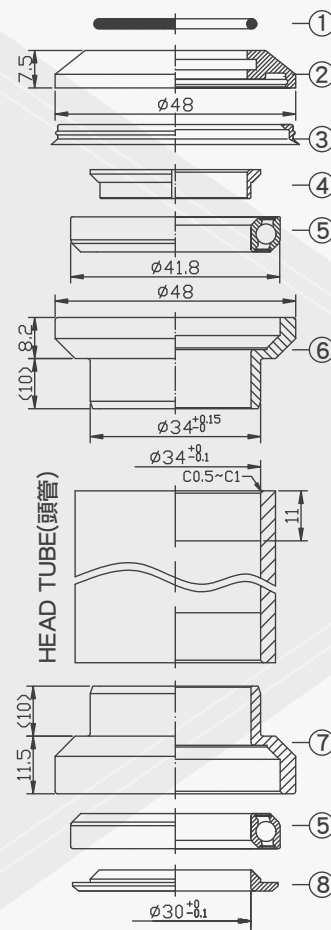

堆積高度(STACK HEIGHT)=29 ± 1mm

NO.	零件名稱 PART NAME	材質 MATERIAL	圖號 DRAWING NO.	台量 Q' TY	尺寸 DIM. DESCRIPTION
1	O形圈 O-Ring	橡膠 NBR	120-8	1	ID28.5xØ2
2	鋁上塞 TOP COVER	鋁合金 6061/T6	773-3	1	1-1/8"
3	防塵蓋 RUBBER SEAL	橡膠 NBR	273-0	1	
4	鋁斜管 COMPRESSION RING	鋁合金 6061/T6	51-2	1	1-1/8"
5	密封式軸承 A.C. SEALED BEARING	軸承鋼 SUJ2	NHB-6B	2	OD 41.8 x 45° x 45°
6	上碗 UPPER CUP	鋁合金 6061/T6	773-4	1	Ø34 ^{+0.15} ₋₀
7	下碗 LOWER CUP	鋁合金 6061/T6	773-5	1	Ø34 ^{+0.15} ₋₀
8	鋁下塞 CROWN RACE	鋁合金 7075/T6	51-6	1	Ø30 ⁺⁰ _{-0.1}

H773L



WEIGHT 151g
SIZE 1.5" Head Tube Reduced to 1-1/8"
Fork Tube External Cup Threadless Headset
SHIS NORM EC34/28.6 | EC49.7/39.8(30)

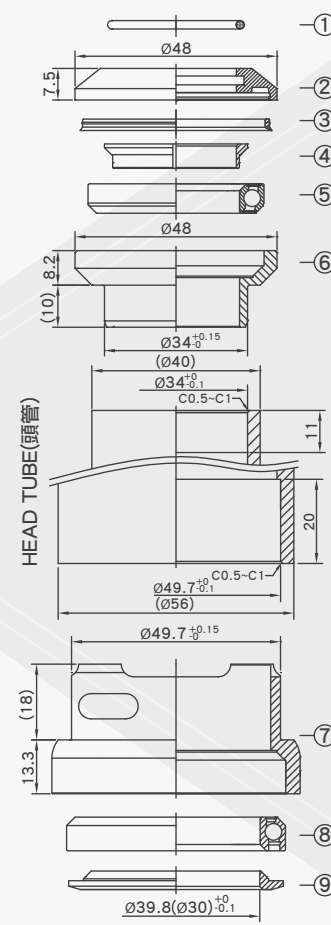

堆積高度(STACK HEIGHT)=30.4 ± 1mm

NO.	零件名稱 PART NAME	材質 MATERIAL	圖號 DRAWING NO.	台量 Q' TY	尺寸 DIM. DESCRIPTION
1	O形圈 O-Ring	橡膠 NBR	120-8	1	ID28.5xØ2
2	鋁上塞 TOP COVER	鋁合金 6061/T6	773-3	1	1-1/8"
3	防塵蓋 RUBBER SEAL	橡膠 NBR	273-0	1	
4	鋁斜管 COMPRESSION RING	鋁合金 6061/T6	51-2	1	1-1/8"
5	密封式軸承 A.C. SEALED BEARING	軸承鋼 SUJ2	NHB-6B	1	OD41.8 x 45° x 45°
6	上碗 UPPER CUP	鋁合金 6061/T6	773-4	1	Ø34 ^{+0.15} ₋₀
7	下碗 LOWER CUP	鋁合金 6061/T6	151A-5	1	Ø49.7 ^{+0.15} ₋₀
8	特大型密封式軸承 OVERSIZE A.C. SEALED BEARING	軸承鋼 SUJ2	NHB-15	1	OD52 x 45° x 45°
9	鋁下塞 CROWN RACE	鋁合金 7075/T6	151-6 (153-6)	1	Ø39.8(Ø30) ⁺⁰ _{-0.1}

H825



WEIGHT 114g
SIZE 1" Threadless Headset
SHIS NORM EC30/25.4 | EC30/27(26.4)

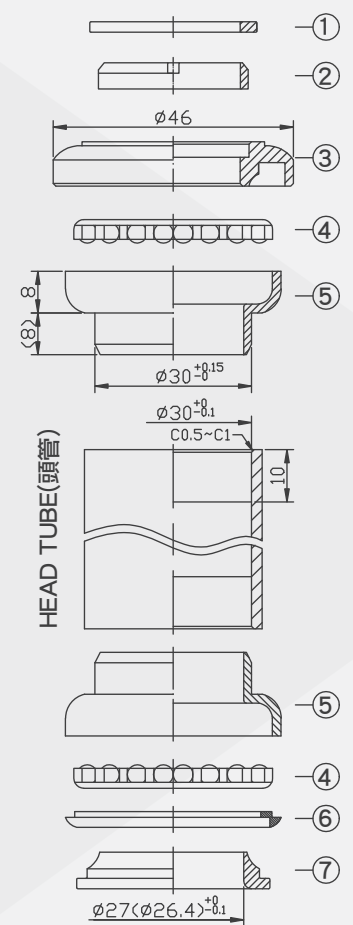

堆積高度(STACK HEIGHT)=25 ± 1mm

NO.	零件名稱 PART NAME	材質 MATERIAL	圖號 DRAWING NO.	台量 Q' TY	尺寸 DIM. DESCRIPTION
1	墊片 SPACER	碳鋼 STEEL	SD3202	1	2txOD32(1")
2	固定圈 COMPRESSING RING	橡膠 NBR	820-2	1	1"
3	上塞 TOP COVER	碳鋼 STEEL	825-3	1	1"
4	珠巢 BALL RETAINER	碳鋼 STEEL		2	5/32"x16
5	碗 CUPS	碳鋼 STEEL	820-5	2	Ø30 ^{+0.15} ₋₀
6	防塵蓋 RUBBER SEAL	橡膠 NBR	831SW-8	1	
7	下塞 CROWN RACE	碳鋼 STEEL	800-6	1	Ø27(Ø26.4) ⁺⁰ _{-0.1}

H827W



WEIGHT 102g
SIZE 1" Threadless Headset
SHIS NORM EC30/25.4 | EC30/27(26.4)

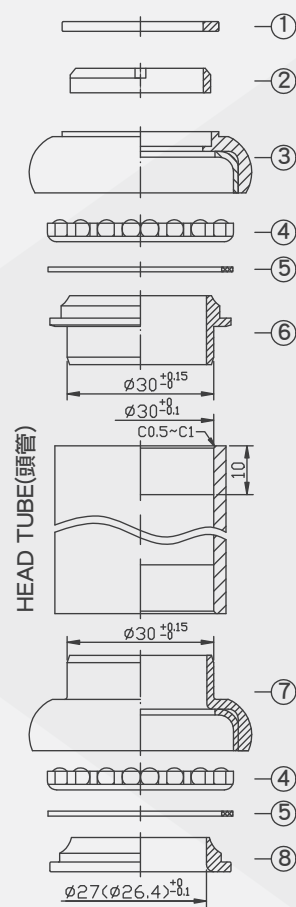

堆積高度(STACK HEIGHT)=28.2 ± 1mm

NO.	零件名稱 PART NAME	材質 MATERIAL	圖號 DRAWING NO.	台量 Q' TY	尺寸 DIM. DESCRIPTION
1	墊片 SPACER	鋁合金 6061/T6	AS3202	1	2txOD32(1")
2	固定圈 COMPRESSING RING	橡膠 NBR	820-2	1	1"
3	鋁上塞 TOP COVER	鋁合金 6061/T6	827W-3	1	1"
4	珠巢 BALL RETAINER	碳鋼 STEEL		2	5/32"x20
5	防水圈 RUBBER SEAL	橡膠 NBR	807W-8	2	
6	上管塞 UPPER CONE	碳鋼 STEEL	807W-4	1	$\phi 30^{+0.15}$ -0
7	鋁下碗 LOWER CUP	鋁合金 6061/T6	807W-5	1	$\phi 30^{+0.15}$ -0
8	下塞 CROWN RACE	碳鋼 STEEL	807-6	1	$\phi 27(\phi 26.4)^{+0.1}$ -0

H845



WEIGHT 142g
SIZE 1-1/8" Threadless Headset
SHIS NORM EC34/28.6 | EC34/30

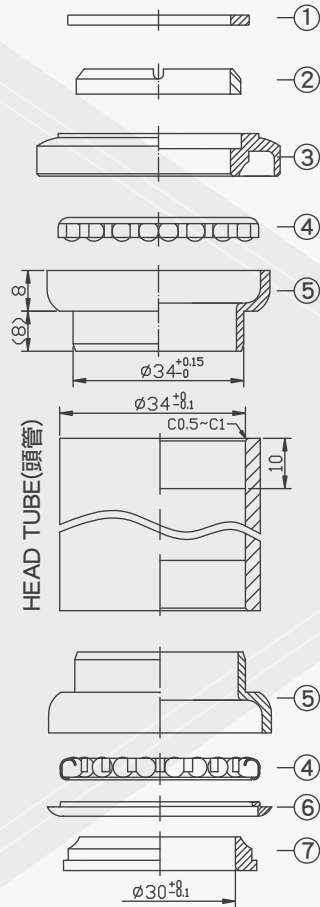

堆積高度(STACK HEIGHT)=26.5 ± 1mm

NO.	零件名稱 PART NAME	材質 MATERIAL	圖號 DRAWING NO.	台量 Q' TY	尺寸 DIM. DESCRIPTION
1	墊片 SPACER	碳鋼 STEEL	SD3602	1	2txOD36(1-1/8")
2	固定圈 COMPRESSING RING	橡膠 NBR	840-2	1	1-1/8"
3	上塞 TOP COVER	碳鋼 STEEL	845-3	1	1-1/8"
4	珠巢 BALL RETAINER	碳鋼 STEEL		2	5/32"x22
5	碗 CUPS	碳鋼 STEEL	841-4	2	$\phi 34^{+0.15}$ -0
6	防水圈 DUST-RESISTANT COVER	塑膠 NYLON	841SW-8	1	
7	下塞 CROWN RACE	碳鋼 STEEL	841-6	1	$\phi 30^{+0.1}$ -0

H846



WEIGHT 144g
SIZE 1-1/8" Threadless Headset
SHIS NORM EC34/28.6 | EC34/30

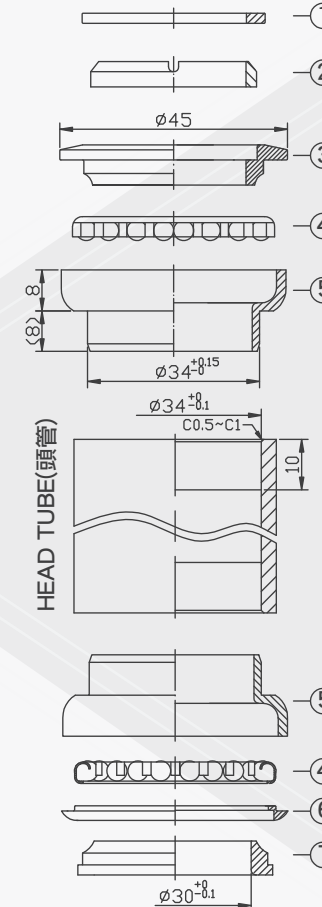

堆積高度(STACK HEIGHT)=25 ± 1mm

NO.	零件名稱 PART NAME	材質 MATERIAL	圖號 DRAWING NO.	台量 Q' TY	尺寸 DIM. DESCRIPTION
1	墊片 SPACER	碳鋼 STEEL	SD3602	1	2txOD36(1-1/8")
2	固定圈 COMPRESSING RING	橡膠 NBR	840-2	1	1-1/8"
3	上塞 TOP COVER	碳鋼 STEEL	846-3	1	1-1/8"
4	珠巢 BALL RETAINER	碳鋼 STEEL		2	5/32"x22
5	碗 CUPS	碳鋼 STEEL	841-4	2	$\phi 34^{+0.15}$ -0
6	防水圈 DUST-RESISTANT COVER	塑膠 NYLON	841SW-8	1	
7	下塞 CROWN RACE	碳鋼 STEEL	841-6	1	$\phi 30^{+0.1}$ -0

H847W



WEIGHT 125g
SIZE 1-1/8" Threadless Headset
SHIS NORM EC34/28.6 | EC34/30

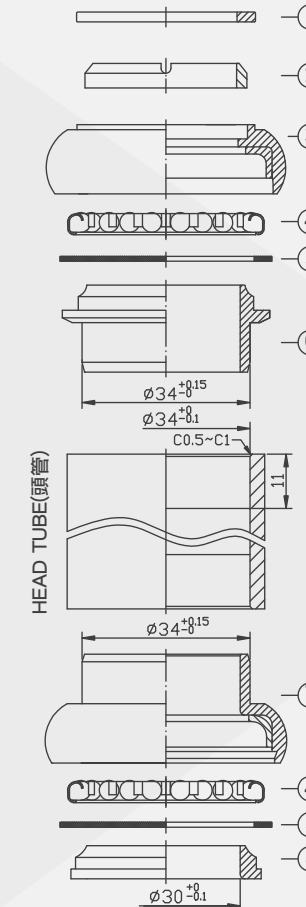

堆積高度(STACK HEIGHT)=31 ± 1mm

NO.	零件名稱 PART NAME	材質 MATERIAL	圖號 DRAWING NO.	台量 Q' TY	尺寸 DIM. DESCRIPTION
1	墊片 SPACER	鋁合金 6061/T6	AS3602	1	2txOD36(1-1/8")
2	固定圈 COMPRESSING RING	橡膠 NBR	840-2	1	1-1/8"
3	鋁上塞 TOP COVER	鋁合金 6061/T6	847W-3	1	1-1/8"
4	珠巢 BALL RETAINER	碳鋼 STEEL		2	5/32"x22
5	防水圈 RUBBER SEAL	橡膠 NBR	815W-8	2	
6	上管塞 UPPER CONE	碳鋼 STEEL	815W-4	1	$\phi 34^{+0.15}$ -0
7	鋁下碗 LOWER CUP	鋁合金 6061/T6	815W-5	1	$\phi 34^{+0.15}$ -0
8	下塞 CROWN RACE	碳鋼 STEEL	841-6 (703-6)	1	$\phi 30^{+0.1}$ -0

H852



WEIGHT 105g
SIZE 1-1/8" Threadless Headset
SHIS NORM EC34/28.6 | EC34/30

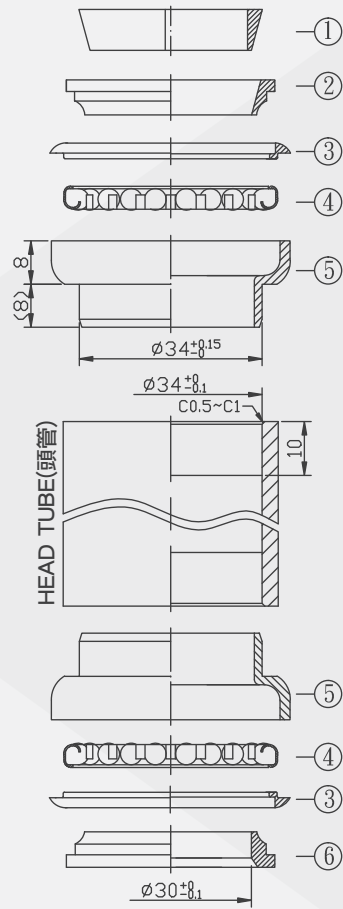

堆積高度(STACK HEIGHT)=22 ± 1mm

NO.	零件名稱 PART NAME	材質 MATERIAL	圖號 DRAWING NO.	台量 Q' TY	尺寸 DIM. DESCRIPTION
1	塑膠斜管 COMPRESSION RING	塑膠 NYLON	115-2	1	1-1/8"
2	上塞 TOP COVER	碳鋼 STEEL	115-3	1	1-1/8"
3	防水圈 DUST-RESISTANT COVER	塑膠 NYLON	841SW-8	2	
4	珠巢 BALL RETAINER	碳鋼 STEEL		2	5/32"x22
5	碗 CUPS	碳鋼 STEEL	841-4	2	$\phi 34^{+0.15}$ -0
6	下塞 CROWN RACE	碳鋼 STEEL	841-6	1	$\phi 30^{+0}$ -0.1

H854



WEIGHT 120g
SIZE 1-1/8" Threadless Headset
SHIS NORM EC34/28.6 | EC34/30

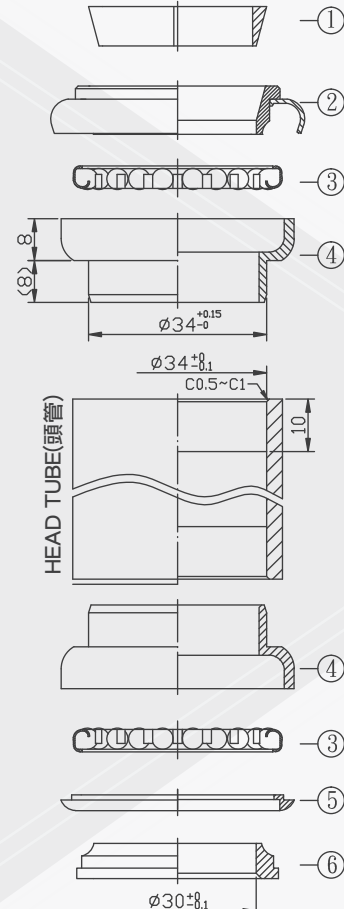

堆積高度(STACK HEIGHT)=25 ± 1mm

NO.	零件名稱 PART NAME	材質 MATERIAL	圖號 DRAWING NO.	台量 Q' TY	尺寸 DIM. DESCRIPTION
1	塑膠斜管 COMPRESSION RING	塑膠 NYLON	115-2	1	1-1/8"
2	上塞 TOP COVER	碳鋼 STEEL	854-3	1	1-1/8"
3	珠巢 BALL RETAINER	碳鋼 STEEL		2	5/32"x22
4	碗 CUPS	碳鋼 STEEL	841-4	2	$\phi 34^{+0.15}$ -0
5	防水圈 DUST-RESISTANT COVER	塑膠 NYLON	841SW-8	1	
6	下塞 CROWN RACE	碳鋼 STEEL	841-6	1	$\phi 30^{+0}$ -0.1

H855 [H826]



WEIGHT 163g
SIZE 1-1/8" Threadless Headset
SHIS NORM EC34/28.6 | EC34/30
OPTIONAL H826 EC30/25.4 | EC30/27(26.4)
STACK HEIGHT=25.6mm

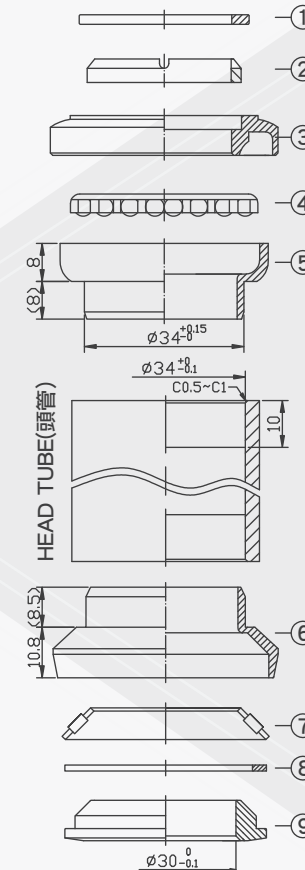

堆積高度(STACK HEIGHT)=28.4 ± 1mm

NO.	零件名稱 PART NAME	材質 MATERIAL	圖號 DRAWING NO.	台量 Q' TY	尺寸 DIM. DESCRIPTION
1	墊片 SPACER	碳鋼 STEEL	SD3602	1	2xOD36
2	固定圈 COMPRESSING RING	橡膠 NBR	840-2	1	1-1/8"
3	上塞 TOP COVER	碳鋼 STEEL	845-3	1	1-1/8"
4	珠巢 BALL RETAINER	碳鋼 STEEL		1	5/32"x22
5	上碗 UPPER CUP	碳鋼 STEEL	841-4	1	$\phi 34^{+0.15}$ -0
6	下碗 LOWER CUP	碳鋼 STEEL	856-5	1	$\phi 34^{+0.15}$ -0
7	條珠珠巢 NEEDLE BEARINGS	碳鋼 STEEL		1	$\phi 2.5 \times 22$
8	防水圈 RUBBER SEAL	橡膠 NBR	856-8	1	
9	條珠下塞 CROWN RACE	碳鋼 STEEL	856-6	1	$\phi 30^{+0}$ -0.1

H867EW [H236EW]



WEIGHT 127g
SIZE 1-1/8" Threadless Headset
SHIS NORM EC34/28.6 | EC34/30
OPTIONAL H236EW EC30/25.4 | EC30/27(26.4)
STACK HEIGHT=28.2mm

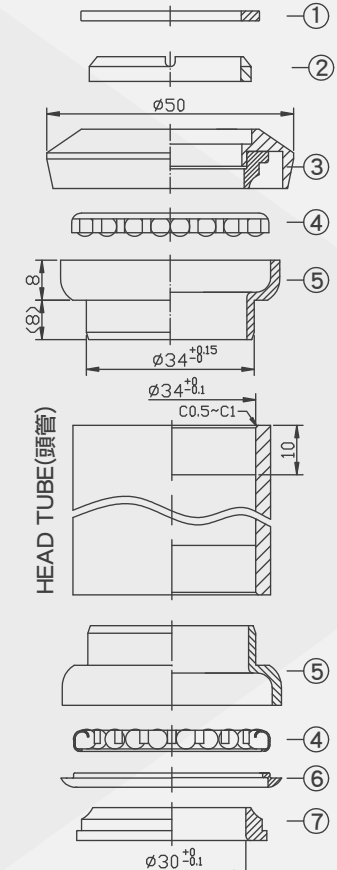

堆積高度(STACK HEIGHT)=28 ± 1mm

NO.	零件名稱 PART NAME	材質 MATERIAL	圖號 DRAWING NO.	台量 Q' TY	尺寸 DIM. DESCRIPTION
1	墊片 SPACER	鋁合金 6061/T6	AS3602	1	2xOD36(1-1/8")
2	固定圈 COMPRESSING RING	橡膠 NBR	840-2	1	1-1/8"
3	鋁上塞 TOP COVER	鋁合金 6061/T6	867W-3	1	1-1/8"
4	珠巢 BALL RETAINER	碳鋼 STEEL		2	5/32"x22
5	碗 CUPS	碳鋼 STEEL	841-4	2	$\phi 34^{+0.15}$ -0
6	防水圈 DUST-RESISTANT COVER	塑膠 NYLON	841SW-8	1	
7	下塞 CROWN RACE	碳鋼 STEEL	841-6	1	$\phi 30^{+0}$ -0.1

H878



WEIGHT 142g
SIZE 1-1/8" Threadless Headset
SHIS NORM EC34/28.6 | EC34/30

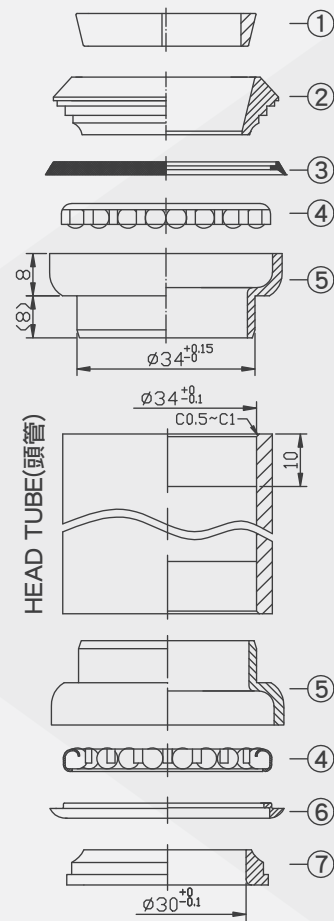

堆積高度(STACK HEIGHT)= 26.5 ± 1 mm

NO.	零件名稱 PART NAME	材質 MATERIAL	圖號 DRAWING NO.	台量 Q' TY	尺寸 DIM. DESCRIPTION
1	斜管 COMPRESSING RING	鋁合金 6061/T6	872-2	1	1-1/8"
2	上塞 TOP COVER	碳鋼 STEEL	878-3	1	1-1/8"
3	防塵蓋 UPPER DUST-RESISTANT COVER	塑膠 NYLON	141-8	1	
4	珠巢 BALL RETAINER	碳鋼 STEEL		2	5/32"x22
5	碗 CUPS	碳鋼 STEEL	841-4	2	$\varnothing 34^{+0.15}$ -0
6	下防水圈 LOWER DUST-RESISTANT COVER	塑膠 NYLON	841SW-8	1	
7	下塞 CROWN RACE	碳鋼 STEEL	841-6	1	$\varnothing 30^{+0}$ -0.1

H879



BIG LOWER CUP
WEIGHT 180g
SIZE 1-1/8" Threadless Headset
SHIS NORM EC34/28.6 | EC34/30

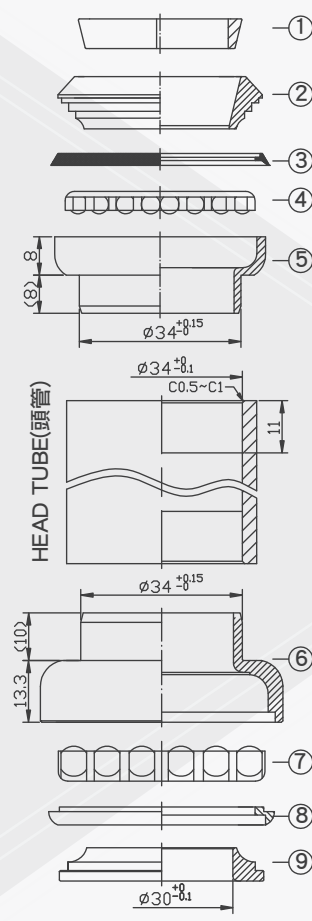

堆積高度(STACK HEIGHT)= 30.4 ± 1 mm

NO.	零件名稱 PART NAME	材質 MATERIAL	圖號 DRAWING NO.	台量 Q' TY	尺寸 DIM. DESCRIPTION
1	斜管 COMPRESSING RING	鋁合金 6061/T6	872-2	1	1-1/8"
2	上塞 TOP COVER	碳鋼 STEEL	878-3	1	1-1/8"
3	防塵蓋 UPPER DUST-RESISTANT COVER	塑膠 NYLON	141-8	1	
4	珠巢 BALL RETAINER	碳鋼 STEEL		1	5/32"x22
5	上碗 UPPER CUP	碳鋼 STEEL	841-4	1	$\varnothing 34^{+0.15}$ -0
6	下碗 LOWER CUP	鉻鉬鋼 CR-MO STEEL	879-5	1	$\varnothing 34^{+0.15}$ -0
7	珠巢 BALL RETAINER	碳鋼 STEEL		1	1/4"x15B
8	下防水圈 LOWER DUST-RESISTANT COVER	塑膠 NYLON	819ESW-8	1	
9	下塞 CROWN RACE	鉻鉬鋼 CR-MO STEEL	879-6	1	$\varnothing 30^{+0}$ -0.1



H128-130

130° 1-1/8"
SAFETY
SEMI-INTEGRATED
HEADSET



WEIGHT 154g
SIZE 1-1/8" Semi- Integrated Threaded Safety Headset
DIMENSIONS Ø25.4x44/50x30

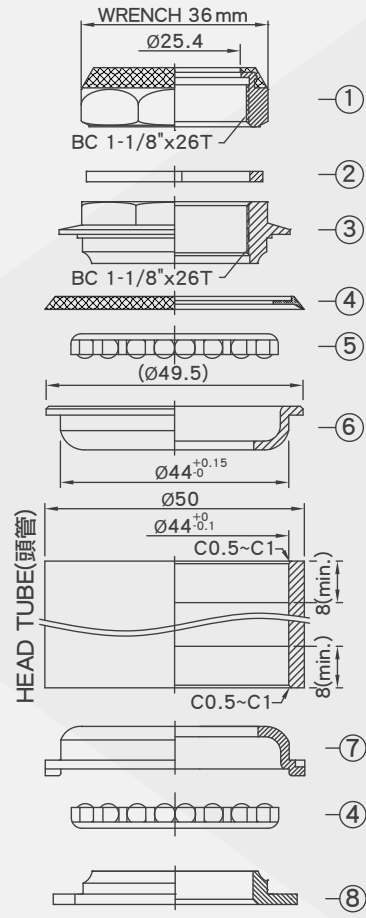

堆積高度(STACK HEIGHT)=26.5±1mm

NO.	零件名稱 PART NAME	材質 MATERIAL	圖號 DRAWING NO.	台量 Q' TY	尺寸 DIM. DESCRIPTION
1	防水上迫緊 LOCK NUT	碳鋼 STEEL	841SW-1	1	BC 1-1/8"x26T
2	有領華司 KEY WASHER	碳鋼 STEEL	SK3402	1	1-1/8"
3	上塞 ADJUSTING CONE	碳鋼 STEEL	128-3	1	BC 1-1/8"x26T
4	防塵蓋 DUST-RESISTANT COVER	塑膠 NYLON	118-8	1	
5	珠巢 BALL RETAINER	碳鋼 STEEL		2	5/32"x22
6	上碗 UPPER CUPS	碳鋼 STEEL	142-4/5	1	Ø44 ^{+0.15} ₋₀
7	安全下碗 LOWER SAFETY CUP	碳鋼 STEEL	142-130-5	1	Ø44 ^{+0.15} ₋₀
8	安全下塞 CROWN RACE	碳鋼 STEEL	142-130-6	1	Ø30 ⁺⁰ _{-0.1}

H130

130° 1"
SAFETY
HEADSET



WEIGHT 127g
SIZE 1" Threaded Safety Headset
DIMENSIONS Ø22.2x30x27

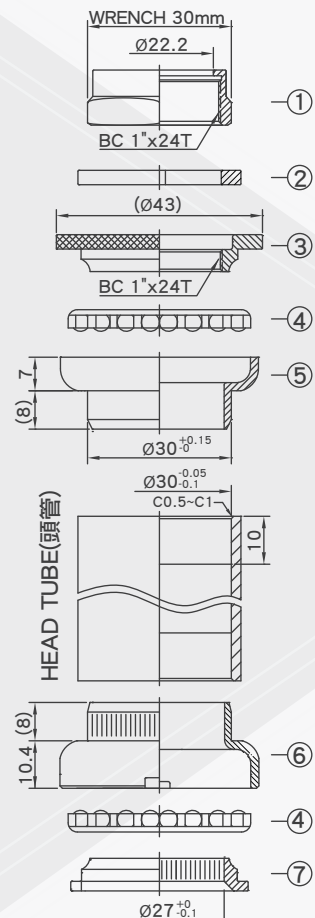

堆積高度(STACK HEIGHT)=34.5±1mm

NO.	零件名稱 PART NAME	材質 MATERIAL	圖號 DRAWING NO.	台量 Q' TY	尺寸 DIM. DESCRIPTION
1	上迫緊 LOCK NUT	碳鋼 STEEL	800-1	1	BC 1"x24T
2	有領華司 KEY WASHER	碳鋼 STEEL	SK3403	1	3txOD34(1")
3	上塞 ADJUSTING CONE	碳鋼 STEEL	800-3	1	BC 1"x24T
4	珠巢 BALL RETAINER	碳鋼 STEEL		2	5/32"x16
5	上碗 UPPER CUP	碳鋼 STEEL	800-4	1	Ø30 ^{+0.15}
6	安全下碗 LOWER CUP	碳鋼 STEEL	130-5	1	Ø30 ^{+0.15}
7	安全下塞 CROWN RACE	碳鋼 STEEL	130-6	1	Ø27 ⁺⁰ _{-0.1}

H134

130° 1"
SAFETY
HEADSET



WEIGHT 116g
SIZE 1" Threadless Safety Headset
DIMENSIONS 1"x30x27

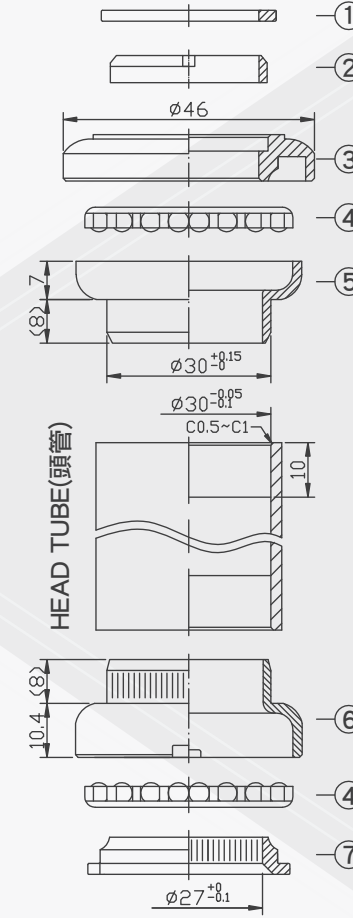

堆積高度(STACK HEIGHT)=25.5±1mm

NO.	零件名稱 PART NAME	材質 MATERIAL	圖號 DRAWING NO.	台量 Q' TY	尺寸 DIM. DESCRIPTION
1	墊片 SPACER	碳鋼 STEEL	SD3202	1	2txOD32(1")
2	固定圈 COMPRESSING RING	橡膠 NBR	820-2	1	1"
3	上塞 ADJUSTING CONE	碳鋼 STEEL	825-3	1	1"
4	珠巢 BALL RETAINER	碳鋼 STEEL		2	5/32"x16
5	上碗 UPPER CUP	碳鋼 STEEL	800-4	1	Ø30 ^{+0.15}
6	安全下碗 LOWER CUP	碳鋼 STEEL	130-5	1	Ø30 ^{+0.15}
7	安全下塞 CROWN RACE	碳鋼 STEEL	130-6	1	Ø27 ⁺⁰ _{-0.1}

H135

130° 1"
SAFETY
HEADSET

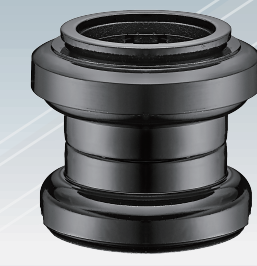

WEIGHT 142g
SIZE 1-1/8" Threadless Safety Headset
DIMENSIONS 1-1/8"x34x30

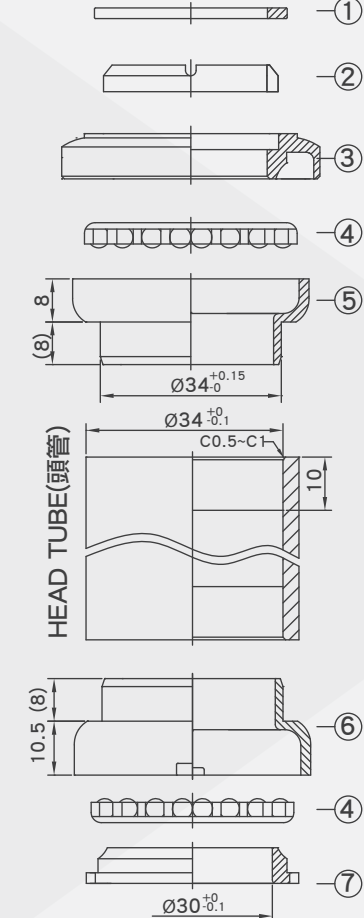

堆積高度(STACK HEIGHT)=27.5±1mm

NO.	零件名稱 PART NAME	材質 MATERIAL	圖號 DRAWING NO.	台量 Q' TY	尺寸 DIM. DESCRIPTION
1	墊片 SPACER	碳鋼 STEEL	SD3602	1	2txOD36(1-1/8")
2	固定圈 COMPRESSING RING	橡膠 NBR	840-2	1	1-1/8"
3	上塞 TOP CONE	碳鋼 STEEL	845-3	1	1-1/8"
4	珠巢 BALL RETAINER	碳鋼 STEEL		2	5/32"x22
5	上碗 CUP	碳鋼 STEEL	841-4	1	Ø34 ^{+0.15}
6	安全下碗 LOWER CUP	碳鋼 STEEL	140-5	1	Ø34 ^{+0.15}
7	安全下塞 CROWN RACE	碳鋼 STEEL	140-6	1	Ø30 ⁺⁰ _{-0.1}

H139

130° 1" SAFETY HEADSET



WEIGHT 136g
SIZE 1" Threaded Safety Headset
DIMENSIONS Ø22.2x30x27

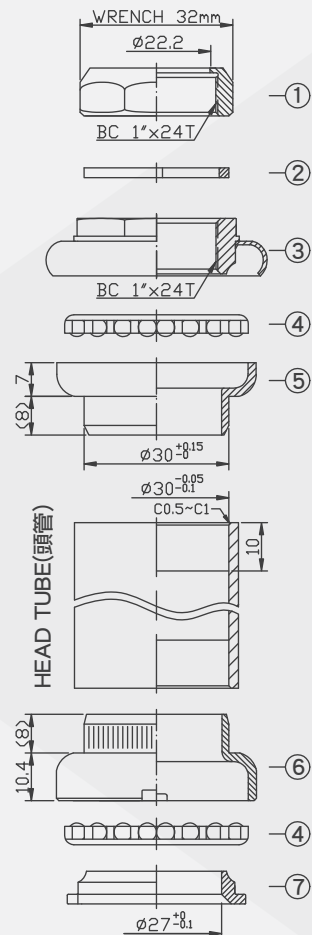

NO.	零件名稱 PART NAME	材質 MATERIAL	圖號 DRAWING NO.	台量 Q' TY	尺寸 DIM. DESCRIPTION
1	上迫緊 LOCK NUT	碳鋼 STEEL	831-1	1	BC 1"x24T
2	有領華司 KEY WASHER	碳鋼 STEEL	SK3002	1	2txOD30(1")
3	上塞 ADJUSTING CONE	碳鋼 STEEL	831-3	1	BC 1"x24T
4	珠巢 BALL RETAINER	碳鋼 STEEL		2	5/32"x16
5	上碗 UPPER CUP	碳鋼 STEEL	800-4	1	Ø30 ^{+0.15}
6	安全下碗 LOWER CUP	碳鋼 STEEL	130-5	1	Ø30 ^{+0.15}
7	安全下塞 CROWN RACE	碳鋼 STEEL	130-6	1	Ø27 ^{+0.1}

H140

130° 1-1/8" SAFETY HEADSET



WEIGHT 164g
SIZE 1-1/8" Threaded Safety Headset
DIMENSIONS 1-1/8"x34x30

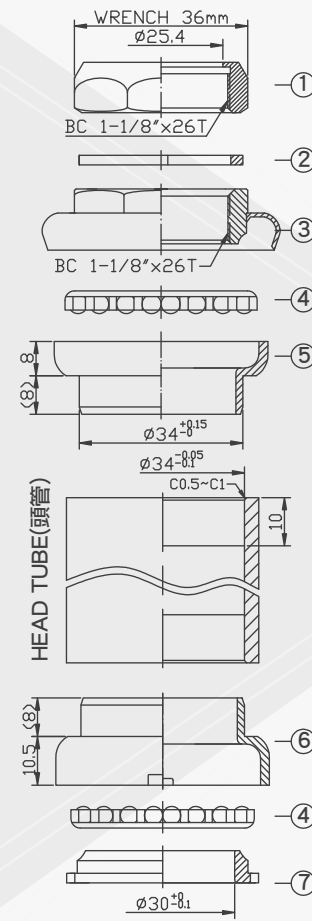

NO.	零件名稱 PART NAME	材質 MATERIAL	圖號 DRAWING NO.	台量 Q' TY	尺寸 DIM. DESCRIPTION
1	上迫緊 LOCK NUT	碳鋼 STEEL	841-1	1	BC 1-1/8"x26T
2	有領華司 KEY WASHER	碳鋼 STEEL	SK3402	1	2txOD34(1-1/8")
3	上塞 ADJUSTING CONE	碳鋼 STEEL	841-3	1	BC 1-1/8"x26T
4	珠巢 BALL RETAINER	碳鋼 STEEL		2	5/32"x22
5	上碗 UPPER CUP	碳鋼 STEEL	841-4	1	Ø34 ^{+0.15}
6	安全下碗 LOWER CUP	碳鋼 STEEL	140-5	1	Ø34 ^{+0.15}
7	安全下塞 CROWN RACE	碳鋼 STEEL	140-6	1	Ø30 ^{+0.1}

H148-130

130° 1-1/8" SAFETY SEMI-INTEGRATED HEADSET



WEIGHT 100.8g
SIZE 1-1/8" Semi-Integrated Threadless Safety Headset
SHIS NORM ZS44/28.6 | ZS44/30

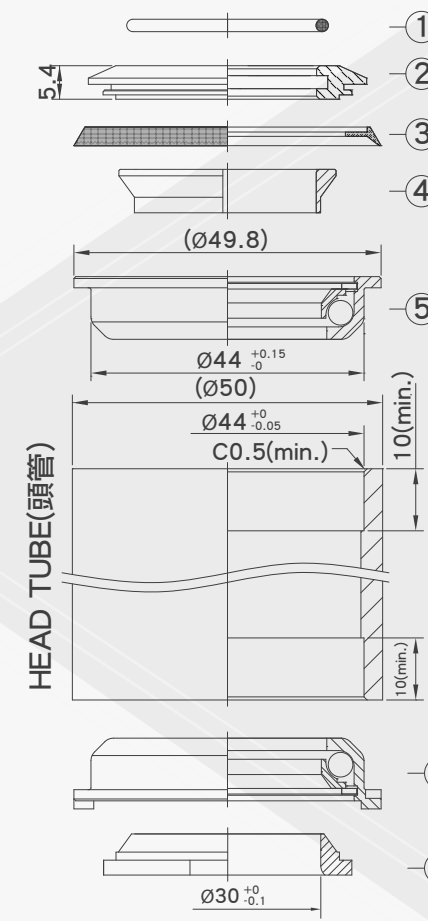

NO.	零件名稱 PART NAME	材質 MATERIAL	圖號 DRAWING NO.	台量 Q' TY	尺寸 DIM. DESCRIPTION
1	O形圈 O-RING	橡膠 NBR	120-8	1	ID2.5xØ2
2	上塞 TOP COVER	鋁合金 6061-T6	125-3	1	1-1/8"
3	防塵蓋 DUST-RESISTANT COVER	塑膠 NYLON	118-8	1	
4	塑膠斜管 COMPRESSION RING	塑膠 NYLON	2036	1	1-1/8"
5	卡式碗 CARTRIDGE STEEL CUP	碳鋼 STEEL	148-4	1	Ø44 ^{+0.15}
6	卡式安全下碗 CARTRIDGE SAFETY CUP	碳鋼 STEEL	148-130-5	1	Ø44 ^{+0.15}
7	安全下塞 CROWN RACE	碳鋼 STEEL	148-130-6	1	Ø30 ^{+0.1}

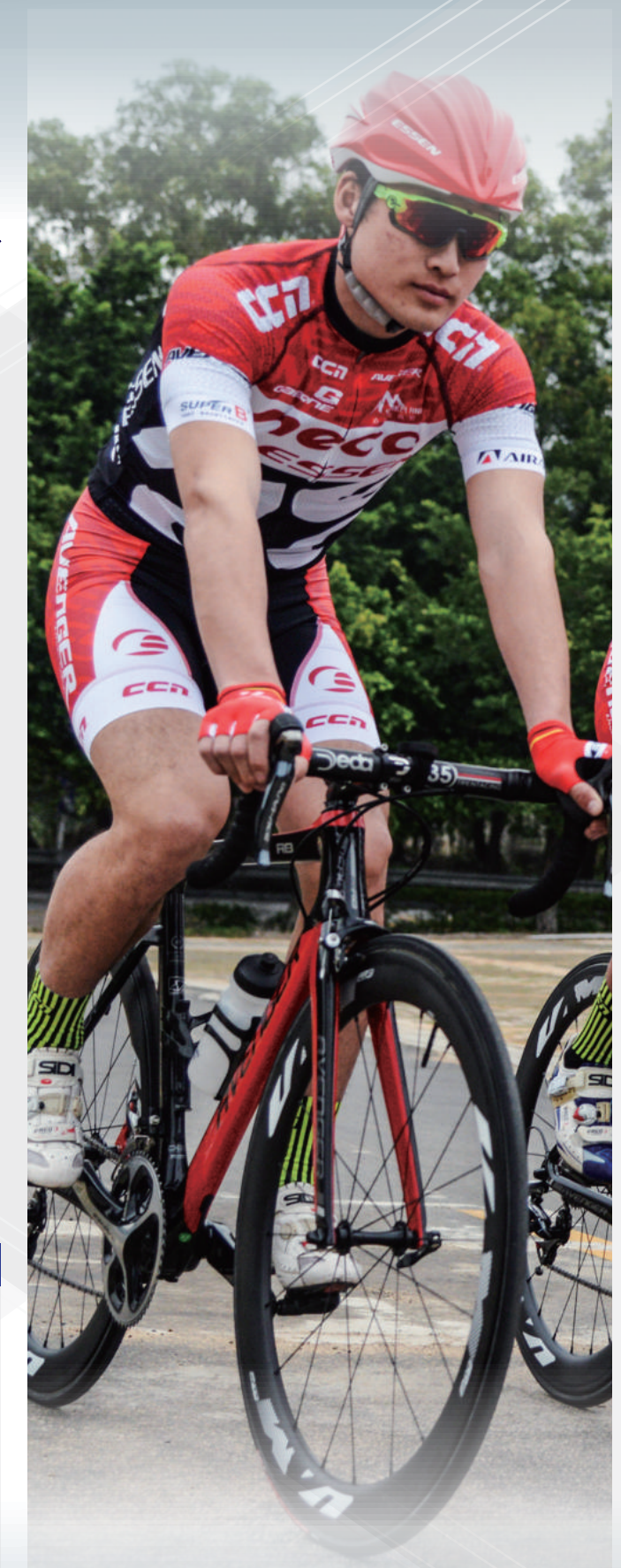

H231



WEIGHT 116.5 g
SIZE 1-1/8"x26T
DIMENSIONS 1-1/8"x34x30

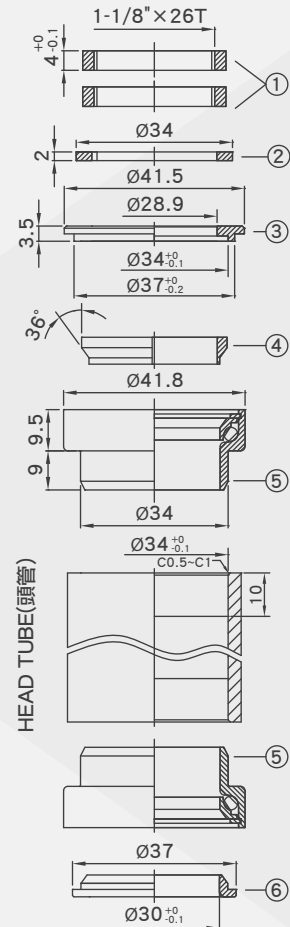

堆積高度(STACK HEIGHT)=40.5 ± 1 mm

NO.	零件名稱 PART NAME	材質 MATERIAL	圖號 DRAWING NO.	台量 QTY	尺寸 DIM. DESCRIPTION
1	二缺牙環 LOCKING RING	碳鋼 STEEL	231-1	2	1-1/8"x26T
2	有領華司 KEY WASHER	碳鋼 STEEL	SK3402	1	2txOD34(1-1/8")
3	上塞 ADJUSTING CONE	鋁合金 6061/T6	231-3	1	1-1/8"
4	鋁斜管 COMPRESSION RING	鋁合金 6061/T6	231-2	1	1-1/8"
5	卡式碗 CARTRIDGE STEEL CUPS	碳鋼 STEEL	231-4/5	2	Ø34 ^{±0.1}
6	下塞 CROWN RACE	碳鋼 STEEL	231-6	1	Ø30 ^{±0.1}

H617



WEIGHT 101.8g
SIZE 1"x24T
DIMENSIONS Ø22.2x30x27(26.4)

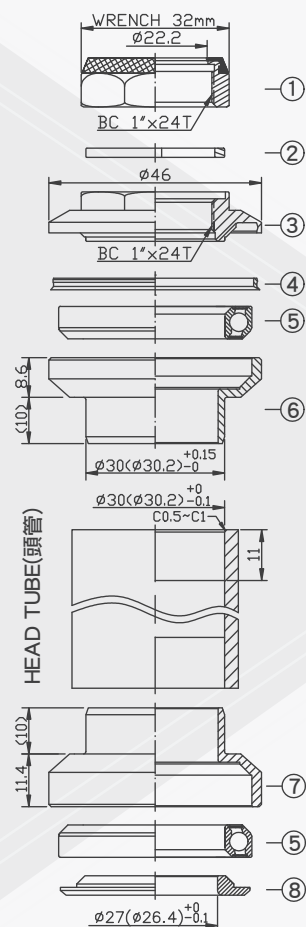

堆積高度(STACK HEIGHT)=40.5 ± 1 mm

NO.	零件名稱 PART NAME	材質 MATERIAL	圖號 DRAWING NO.	台量 QTY	尺寸 DIM. DESCRIPTION
1	鋁防上迫緊 LOCK NUT WITH SEAL	鋁合金 6061/T6	807W-1	1	BC 1"x24T
2	有領華司 KEY WASHER	碳鋼 STEEL	SK3002	1	2txOD30
3	鋁上塞 ADJUSTING CONE	鋁合金 6061/T6	617-3	1	BC 1"x24T
4	防塵蓋 RUBBER SEAL	橡膠 NBR	273-0	1	
5	密封式軸承 A.C. SEALED BEARING	軸承鋼 SUJ2	NHB-6B	2	OD41.8x45"x45"
6	鋁上碗 UPPER CUP	鋁合金 6061/T6	610-4	1	Ø30 (Ø30.2) ^{±0.15}
7	鋁下碗 LOWER CUP	鋁合金 6061/T6	610-5	1	Ø30 (Ø30.2) ^{±0.15}
8	鋁下塞 CROWN RACE	鋁合金 7075/T6	05-6	1	Ø27 (Ø26.4) ^{±0.1}

H671



WEIGHT 117g
SIZE 1"x24T
DIMENSIONS Ø22.2x30x27(26.4)

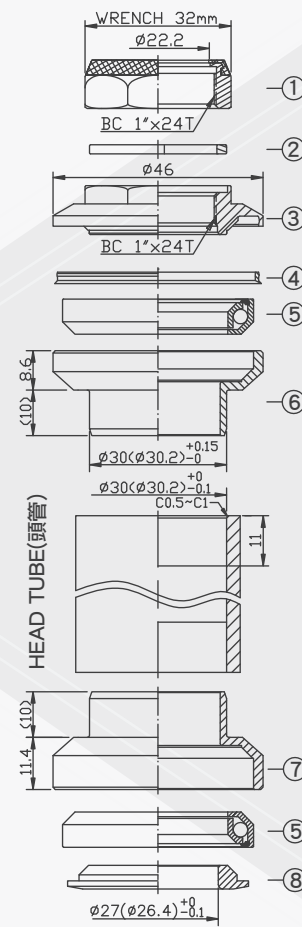

堆積高度(STACK HEIGHT)=40.5 ± 1 mm

NO.	零件名稱 PART NAME	材質 MATERIAL	圖號 DRAWING NO.	台量 QTY	尺寸 DIM. DESCRIPTION
1	鋁防水上迫緊 LOCK NUT WITH SEAL	鋁合金 6061/T6	807W-1	1	BC 1"x24T
2	有領華司 KEY WASHER	碳鋼 STEEL	SK3002	1	2txOD30
3	鋁上塞 ADJUSTING CONE	鋁合金 6061/T6	671-3	1	BC 1"x24T
4	防塵蓋 RUBBER SEAL	橡膠 NBR	273-0	1	
5	卡式軸承 CARTRIDGE BALL BEARING	鉻鉬鋼 CR-MO	CBB-418	2	OD41.8x45"x45"
6	鋁上碗 UPPER CUP	鋁合金 6061/T6	610-4	1	Ø30 (Ø30.2) ^{±0.15}
7	鋁下碗 LOWER CUP	鋁合金 6061/T6	610-5	1	Ø30 (Ø30.2) ^{±0.15}
8	下塞 CROWN RACE	碳鋼 STEEL	671-6	1	Ø27 (Ø26.4) ^{±0.1}

H717



WEIGHT 116g
SIZE 1-1/8"x26T
DIMENSIONS Ø25.4x34x30

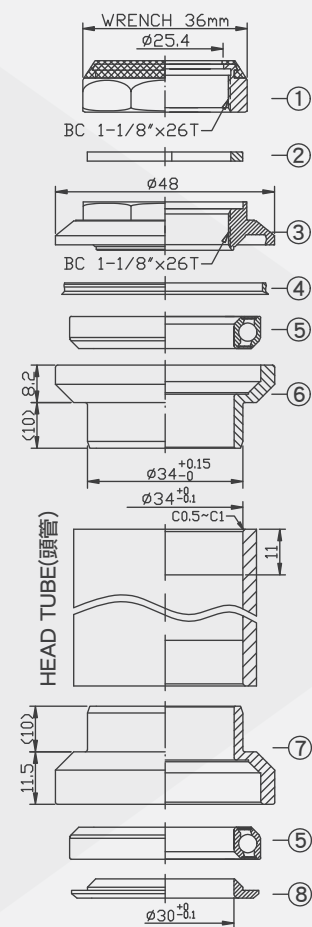

堆積高度(STACK HEIGHT)=40.5 ± 1 mm

NO.	零件名稱 PART NAME	材質 MATERIAL	圖號 DRAWING NO.	台量 QTY	尺寸 DIM. DESCRIPTION
1	鋁防水上迫緊 LOCK NUT WITH SEAL	鋁合金 6061/T6	815W-1	1	BC 1-1/8"x26T
2	有領華司 KEY WASHER	碳鋼 STEEL	SK3402	1	2txOD34(1-1/8")
3	鋁上塞 ADJUSTING CONE	鋁合金 6061/T6	717-3	1	BC 1-1/8"x26T
4	防塵蓋 RUBBER SEAL	橡膠 NBR	273-0	1	
5	密封式軸承 A.C. SEALED BEARING	軸承鋼 SUJ2	NHB-6B	2	OD41.8x45"x45"
6	鋁上碗 UPPER CUP	鋁合金 6061/T6	773-4	1	Ø34 ^{±0.15}
7	鋁下碗 LOWER CUP	鋁合金 6061/T6	773-5	1	Ø34 ^{±0.15}
8	鋁下塞 CROWN RACE	鋁合金 7075/T6	51-6	1	Ø30 ^{±0.1}

外露式有牙車頭碗
EXTERNAL CUP THREADED HEADSETS

H771



WEIGHT 120g
SIZE 1-1/8"x26T
DIMENSIONS $\varnothing 25.4 \times 34 \times 30$

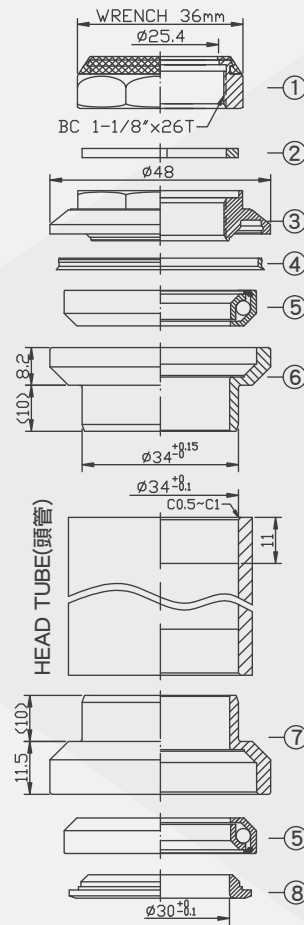

堆積高度(STACK HEIGHT)= 40.8 ± 1 mm

NO.	零件名稱 PART NAME	材質 MATERIAL	圖號 DRAWING NO.	台量 Q'TY	尺寸 DIM. DESCRIPTION
1	鋁防水上迫緊 LOCK NUT WITH SEAL	鋁合金 6061/T6	815W-1	1	BC 1-1/8"x26T
2	有領華司 KEY WASHER	碳鋼 STEEL	SK3402	1	2txOD34(1-1/8")
3	鋁上塞 ADJUSTING CONE	鋁合金 6061/T6	771-3	1	BC 1-1/8"x26T
4	防塵蓋 RUBBER SEAL	橡膠 NBR	273-0	1	
5	卡式軸承 CARTRIDGE BALL BEARING	鉻鉬鋼 CR-MO	CBB-418	2	OD41.8x45"x45"
6	鋁上碗 UPPER CUP	鋁合金 6061/T6	773-4	1	$\varnothing 34^{+0.15}$
7	鋁下碗 LOWER CUP	鋁合金 6061/T6	773-5	1	$\varnothing 34^{+0.15}$
8	鋁下塞 CROWN RACE	碳鋼 STEEL	52-6	1	$\varnothing 30^{+0.1}$

H800K



WEIGHT 123g
SIZE 1"x24T
DIMENSIONS $\varnothing 22.2 \times 30 \times 27(26.4)$
*OPTIONAL H800D Plain Washer (w/o nose)
H800T Threaded Washer
H800C Semi-Cartridge Cups

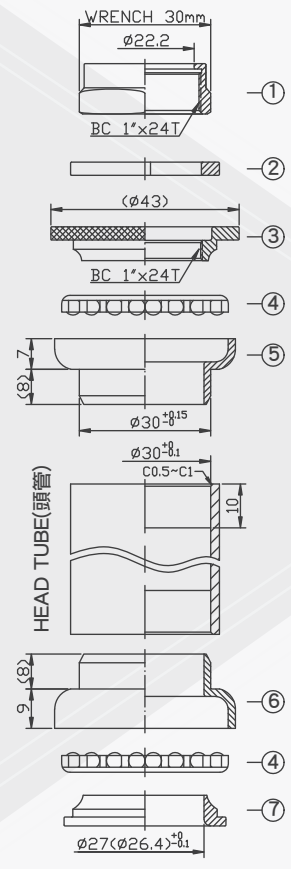

堆積高度(STACK HEIGHT)= 34.3 ± 1 mm

NO.	零件名稱 PART NAME	材質 MATERIAL	圖號 DRAWING NO.	台量 Q'TY	尺寸 DIM. DESCRIPTION
1	上迫緊 LOCK NUT	碳鋼 STEEL	800-1	1	BC 1"x24T
2	有領華司 KEY WASHER	碳鋼 STEEL	SK3403	1	3txOD34(1")
3	上塞 ADJUSTING CONE	碳鋼 STEEL	800-3	1	BC 1"x24T
4	珠巢 BALL RETAINER	碳鋼 STEEL		2	5/32"x16
5	上碗 UPPER CUP	碳鋼 STEEL	800-4	1	$\varnothing 30^{+0.15}$
6	下碗 LOWER CUP	碳鋼 STEEL	800-5	1	$\varnothing 30^{+0.1}$
7	下塞 CROWN RACE	碳鋼 STEEL	800-6	1	$\varnothing 27(\varnothing 26.4)^{+0.1}$

H801K



WEIGHT 139g
SIZE 1"x24T
DIMENSIONS $\varnothing 22.2 \times 30 \times 27(26.4)$

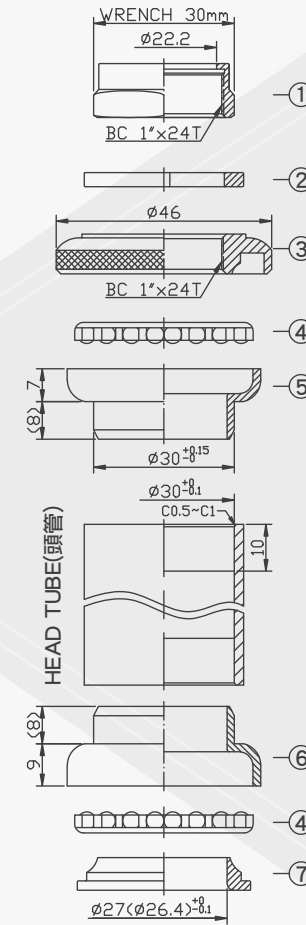

堆積高度(STACK HEIGHT)= 36 ± 1 mm

NO.	零件名稱 PART NAME	材質 MATERIAL	圖號 DRAWING NO.	台量 Q'TY	尺寸 DIM. DESCRIPTION
1	上迫緊 LOCK NUT	碳鋼 STEEL	800-1	1	BC 1"x24T
2	有領華司 KEY WASHER	碳鋼 STEEL	SK3403	1	3txOD34(1")
3	上塞 ADJUSTING CONE	碳鋼 STEEL	801-3	1	BC 1"x24T
4	珠巢 BALL RETAINER	碳鋼 STEEL		2	5/32"x16
5	上碗 UPPER CUP	碳鋼 STEEL	800-4	1	$\varnothing 30^{+0.15}$
6	下碗 LOWER CUP	碳鋼 STEEL	800-5	1	$\varnothing 30^{+0.15}$
7	下塞 CROWN RACE	碳鋼 STEEL	800-6	1	$\varnothing 27(\varnothing 26.4)^{+0.1}$

H802AK



WEIGHT 150g
SIZE 1"x24T
DIMENSIONS $\varnothing 21.1 \times 32.5 \times 27$

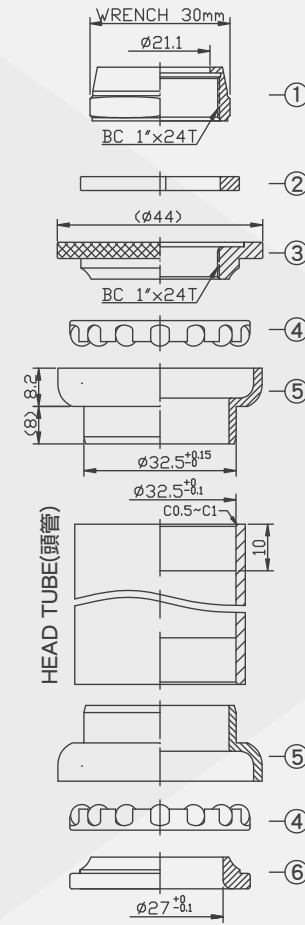

堆積高度(STACK HEIGHT)= 36 ± 1 mm

NO.	零件名稱 PART NAME	材質 MATERIAL	圖號 DRAWING NO.	台量 Q'TY	尺寸 DIM. DESCRIPTION
1	上迫緊 LOCK NUT	碳鋼 STEEL	800A-1	1	BC 1"x24T
2	有領華司 KEY WASHER	碳鋼 STEEL	SK3403	1	3txOD34(1")
3	上塞 ADJUSTING CONE	碳鋼 STEEL	802-3	1	BC 1"x24T
4	珠巢 BALL RETAINER	碳鋼 STEEL		2	3/16"x15
5	碗 CUPS	碳鋼 STEEL	802-4	2	$\varnothing 32.5^{+0.15}$
6	下塞 CROWN RACE	碳鋼 STEEL	802-6	1	$\varnothing 27^{+0.1}$

外露式有牙車頭碗
EXTERNAL CUP THREADED HEADSETS

外露式有牙車頭碗
EXTERNAL CUP THREADED HEADSETS

H806

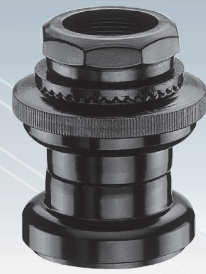

WEIGHT 144.7g
SIZE 1"x24T
DIMENSIONS $\varnothing 22.2 \times 30 \times 27 (26.4)$

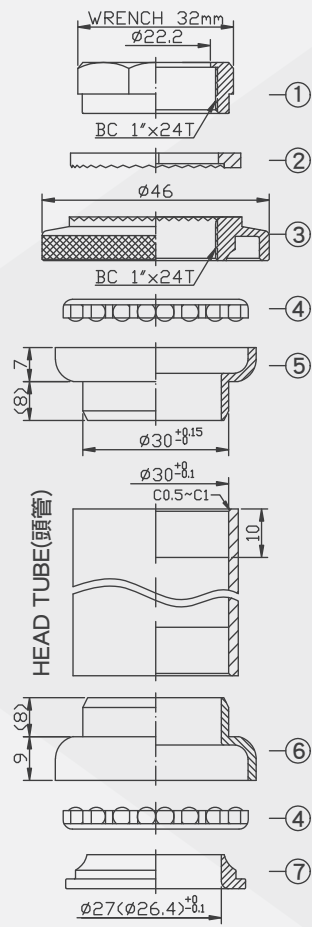

堆積高度(STACK HEIGHT)=35 ± 1mm

NO.	零件名稱 PART NAME	材質 MATERIAL	圖號 DRAWING NO.	台量 Q' TY	尺寸 DIM. DESCRIPTION
1	上迫緊 LOCK NUT	碳鋼 STEEL	806-1	1	BC 1"x24T
2	粗齒華司 WASHER	碳鋼 STEEL	806-2	1	3t(1")
3	粗齒上塞 ADJUSTING CONE	碳鋼 STEEL	806-3	1	BC 1"x24T
4	珠巢 BALL RETAINER	碳鋼 STEEL		2	5/32"x16
5	上碗 UPPER CUP	碳鋼 STEEL	800-4	1	$\varnothing 30^{+0.15}$
6	下碗 LOWER CUP	碳鋼 STEEL	800-5	1	$\varnothing 30^{+0.15}$
7	下塞 CROWN RACE	碳鋼 STEEL	800-6	1	$\varnothing 27(\varnothing 26.4)^{+0.1}$

H807W



WEIGHT 115g
SIZE 1"x24T
DIMENSIONS $\varnothing 22.2 \times 30 \times 27 (26.4)$

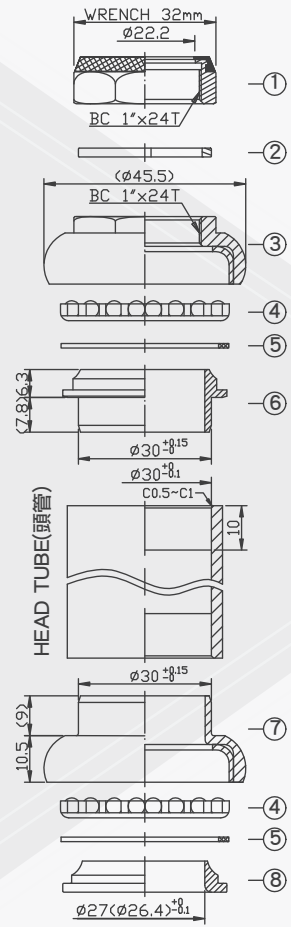

堆積高度(STACK HEIGHT)=39.5 ± 1mm

NO.	零件名稱 PART NAME	材質 MATERIAL	圖號 DRAWING NO.	台量 Q' TY	尺寸 DIM. DESCRIPTION
1	鋁防水上迫緊 LOCK NUT WITH SEAL	鋁合金 6061/T6	807W-1	1	BC 1"x24T
2	有領華司 KEY WASHER	碳鋼 STEEL	SK3002	1	2txOD30(1")
3	鋁上塞 ADJUSTING CONE	鋁合金 6061/T6	807W-3	1	BC 1"x24T
4	珠巢 BALL RETAINER	碳鋼 STEEL		2	5/32"x20
5	防水圈 RUBBER SEAL	橡膠 NBR	807W-8	2	
6	上管塞 UPPER CONE	碳鋼 STEEL	807W-4	1	$\varnothing 30^{+0.15}$
7	鋁下碗 LOWER CUP	鋁合金 6061/T6	807W-5	1	$\varnothing 30^{+0.15}$
8	下塞 CROWN RACE	碳鋼 STEEL	807-6	1	$\varnothing 27(\varnothing 26.4)^{+0.1}$

H815W



WEIGHT 145g
SIZE 1-1/8"x26T
DIMENSIONS $\varnothing 25.4 \times 34 \times 30$

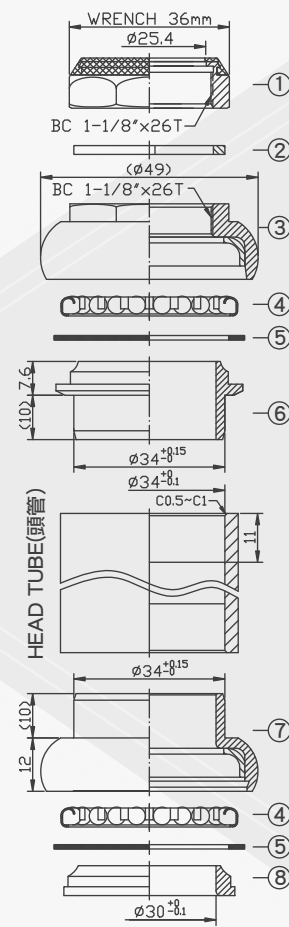

堆積高度(STACK HEIGHT)=43 ± 1mm

NO.	零件名稱 PART NAME	材質 MATERIAL	圖號 DRAWING NO.	台量 Q' TY	尺寸 DIM. DESCRIPTION
1	鋁防水上迫緊 LOCK NUT WITH SEAL	鋁合金 6061/T6	815W-1	1	BC 1-1/8"x26T
2	有領華司 KEY WASHER	碳鋼 STEEL	SK3402	1	2txOD34(1-1/8")
3	鋁上塞 ADJUSTING CONE	鋁合金 6061/T6	815W-3	1	BC 1-1/8"x26T
4	珠巢 BALL RETAINER	碳鋼 STEEL		2	5/32"x22
5	防水圈 RUBBER SEAL	橡膠 NBR	815W-8	2	
6	上管塞 UPPER CONE	碳鋼 STEEL	815W-4	1	$\varnothing 34^{+0.15}$
7	鋁下碗 LOWER CUP	鋁合金 6061/T6	815W-5	1	$\varnothing 34^{+0.15}$
8	下塞 CROWN RACE	碳鋼 STEEL	841-6 (703-6)	1	$\varnothing 30^{+0.1}$

H831

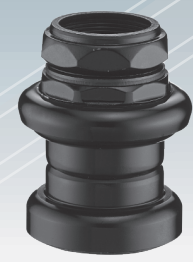

WEIGHT 134g
SIZE 1"x24T
DIMENSIONS $\varnothing 22.2 \times 30 \times 27 (26.4)$

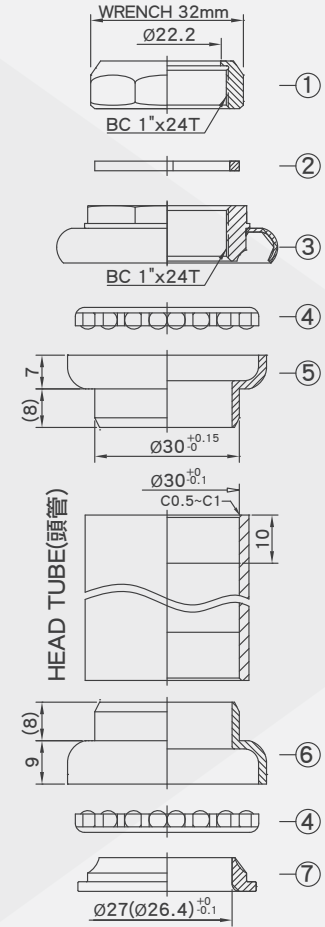

堆積高度(STACK HEIGHT)=36.5 ± 1mm

NO.	零件名稱 PART NAME	材質 MATERIAL	圖號 DRAWING NO.	台量 Q' TY	尺寸 DIM. DESCRIPTION
1	上迫緊 LOCK NUT	碳鋼 STEEL	831-1	1	BC 1"x24T
2	有領華司 KEY WASHER	碳鋼 STEEL	SK3002	1	2txOD30(1")
3	上塞 ADJUSTING CONE	碳鋼 STEEL	831-3	1	BC 1"x24T
4	珠巢 BALL RETAINER	碳鋼 STEEL		2	5/32"x16
5	上碗 UPPER CUP	碳鋼 STEEL	800-4	1	$\varnothing 30^{+0.15}$
6	下碗 LOWER CUP	碳鋼 STEEL	800-5	1	$\varnothing 30^{+0.15}$
7	下塞 CROWN RACE	碳鋼 STEEL	800-6	1	$\varnothing 27(\varnothing 26.4)^{+0.1}$

外露式有牙車頭碗
EXTERNAL CUP THREADED HEADSETS

H831CW

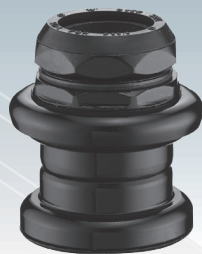

WEIGHT 140.1g
SIZE 1"x24T
DIMENSIONS $\varnothing 22.2 \times 30 \times 27 (26.4)$

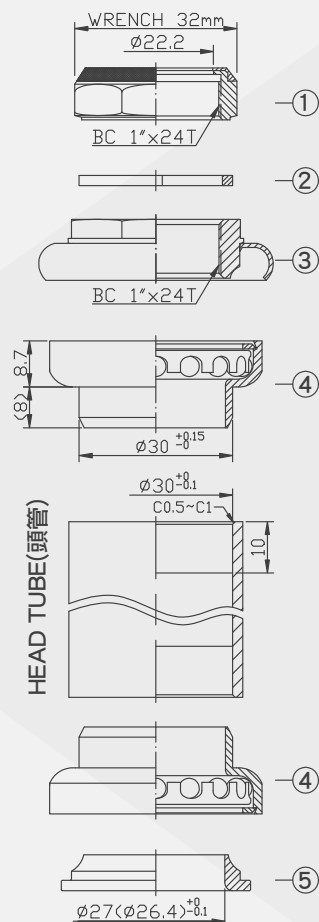

堆積高度(STACK HEIGHT)= 36.5 ± 1 mm

NO.	零件名稱 PART NAME	材質 MATERIAL	圖號 DRAWING NO.	台量 Q' TY	尺寸 DIM. DESCRIPTION
1	防水上迫緊 LOCK NUT WITH SEAL	碳鋼 STEEL	831SW-1	1	BC 1"x24T
2	有領華司 KEY WASHER	碳鋼 STEEL	SK3002	1	2txOD30(1")
3	上塞 ADJUSTING CONE	碳鋼 STEEL	831-3	1	BC 1"x24T
4	半卡式碗 SEMI-CARTRIDGE STEEL CUP	碳鋼 STEEL	800C-4/5	2	$\varnothing 30^{+0.15}$
5	下塞 CROWN RACE	碳鋼 STEEL	800-6	1	$\varnothing 27(\varnothing 26.4)^{+0.1}_{-0.1}$

H831SW



WEIGHT 134g
SIZE 1"x24T
DIMENSIONS $\varnothing 22.2 \times 30 \times 27 (26.4)$

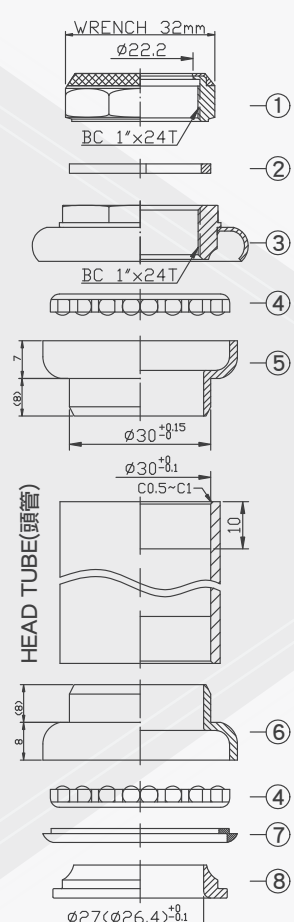

堆積高度(STACK HEIGHT)= 36.5 ± 1 mm

NO.	零件名稱 PART NAME	材質 MATERIAL	圖號 DRAWING NO.	台量 Q' TY	尺寸 DIM. DESCRIPTION
1	防水上迫緊 LOCK NUT WITH SEAL	碳鋼 STEEL	831SW-1	1	BC 1"x24T
2	有領華司 KEY WASHER	碳鋼 STEEL	SK3002	1	2txOD30(1")
3	上塞 ADJUSTING CONE	碳鋼 STEEL	831-3	1	BC 1"x24T
4	珠巢 BALL RETAINER	碳鋼 STEEL		2	5/32"x16
5	上碗 UPPER CUP	碳鋼 STEEL	800-4	1	$\varnothing 30^{+0.15}$
6	下碗 LOWER CUP	碳鋼 STEEL	820-5	1	$\varnothing 30^{+0.15}$
7	防水圈 DUST-RESISTANT COVER	塑膠 NYLON	831SW-8	1	
8	下塞 CROWN RACE	碳鋼 STEEL	800-6	1	$\varnothing 27(\varnothing 26.4)^{+0.1}_{-0.1}$

H833K



WEIGHT 127.8g
SIZE 1-1/8" Head Tube Reduced to
1" Fork Tube Threaded Headset
DIMENSIONS $\varnothing 22.2 \times 34 \times 27 (26.4)$

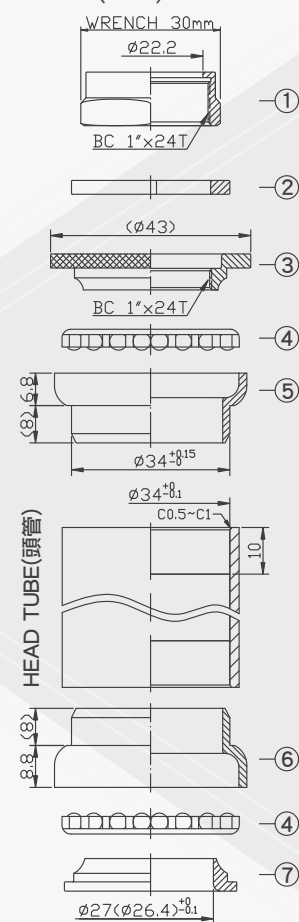

堆積高度(STACK HEIGHT)= 33.5 ± 1 mm

NO.	零件名稱 PART NAME	材質 MATERIAL	圖號 DRAWING NO.	台量 Q' TY	尺寸 DIM. DESCRIPTION
1	上迫緊 LOCK NUT	碳鋼 STEEL	800-1	1	BC 1"x24T
2	有領華司 KEY WASHER	碳鋼 STEEL	SK3403	1	3txOD34(1")
3	上塞 ADJUSTING CONE	碳鋼 STEEL	800-3	1	BC 1"x24T
4	珠巢 BALL RETAINER	碳鋼 STEEL		2	5/32"x16
5	上碗 UPPER CUP	碳鋼 STEEL	834-4	1	$\varnothing 34^{+0.15}$
6	下碗 LOWER CUP	碳鋼 STEEL	834-5	1	$\varnothing 34^{+0.15}$
7	下塞 CROWN RACE	碳鋼 STEEL	800-6	1	$\varnothing 27(\varnothing 26.4)^{+0.1}_{-0.1}$

H834SW



WEIGHT 139.4g
SIZE 1-1/8" Head Tube Reduced to
1" Fork Tube Threaded Headset
DIMENSIONS $\varnothing 22.2 \times 34 \times 27 (26.4)$

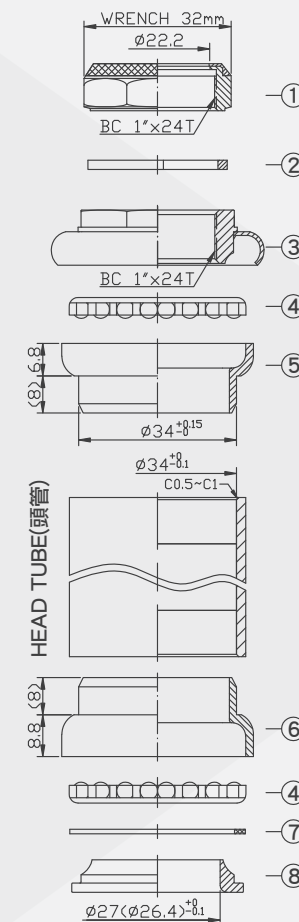

堆積高度(STACK HEIGHT)= 36 ± 1 mm

NO.	零件名稱 PART NAME	材質 MATERIAL	圖號 DRAWING NO.	台量 Q' TY	尺寸 DIM. DESCRIPTION
1	防水上迫緊 LOCK NUT WITH SEAL	碳鋼 STEEL	831SW-1	1	BC 1"x24T
2	有領華司 KEY WASHER	碳鋼 STEEL	SK3002	1	2txOD30(1")
3	上塞 ADJUSTING CONE	碳鋼 STEEL	831-3	1	BC 1"x24T
4	珠巢 BALL RETAINER	碳鋼 STEEL		2	5/32"x16
5	上碗 UPPER CUP	碳鋼 STEEL	834-4	1	$\varnothing 34^{+0.15}$
6	下碗 LOWER CUP	碳鋼 STEEL	834-5	1	$\varnothing 34^{+0.15}$
7	防水圈 RUBBER SEAL	橡膠 NBR	807W-8	1	
8	下塞 CROWN RACE	碳鋼 STEEL	800-6	1	$\varnothing 27(\varnothing 26.4)^{+0.1}_{-0.1}$

H841G

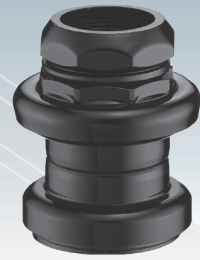

WEIGHT 160.2g
SIZE 1-1/8"x26T
DIMENSIONS Ø28.6x34x30

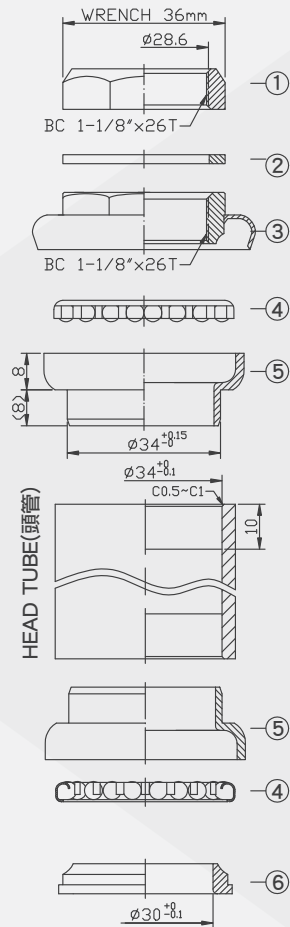

堆積高度(STACK HEIGHT)=37.5±1mm

NO.	零件名稱 PART NAME	材質 MATERIAL	圖號 DRAWING NO.	台量 Q' TY	尺寸 DIM. DESCRIPTION
1	通孔上迫緊 LOCK NUT WITH SEAL (GO THROUGH)	碳鋼 STEEL	841G-1	1	BC 1-1/8"x26T
2	中圈華司 PLAIN WASHER	碳鋼 STEEL	SD3602	1	2txOD36(1-1/8")
3	上塞 ADJUSTING CONE	碳鋼 STEEL	841-3	1	BC 1-1/8"x26T
4	珠巢 BALL RETAINER	碳鋼 STEEL		2	5/32"x22
5	碗 CUPS	碳鋼 STEEL	841-4	2	Ø34 ^{+0.15}
6	下塞 CROWN RACE	碳鋼 STEEL	841-6	1	Ø30 ^{+0.1}

H841CW

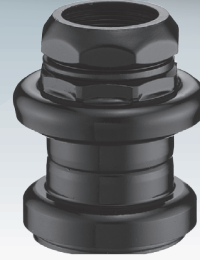

WEIGHT 171.4g
SIZE 1-1/8"x26T
DIMENSIONS Ø25.4x34x30

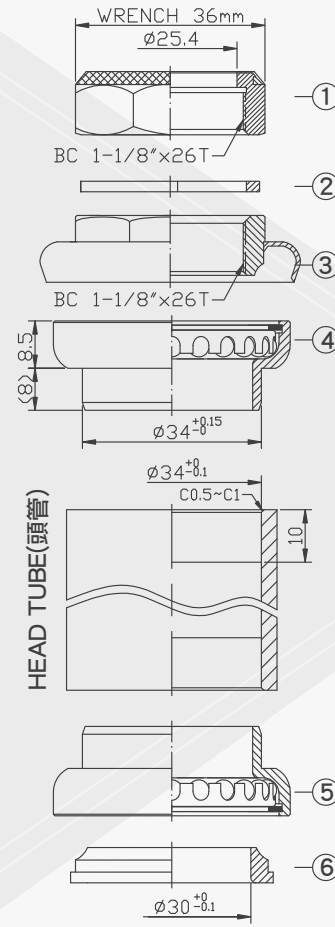

堆積高度(STACK HEIGHT)=38±1mm

NO.	零件名稱 PART NAME	材質 MATERIAL	圖號 DRAWING NO.	台量 Q' TY	尺寸 DIM. DESCRIPTION
1	防水上迫緊 LOCK NUT WITH SEAL	碳鋼 STEEL	841SW-1	1	BC 1-1/8"x26T
2	有領華司 KEY WASHER	碳鋼 STEEL	SK3402	1	2txOD34(1-1/8")
3	上塞 ADJUSTING CONE	碳鋼 STEEL	841-3	1	BC 1-1/8"x26T
4	半卡式碗 SEMI-CARTRIDGE STEEL CUP	碳鋼 STEEL	841C-4/5	2	Ø34 ^{+0.15}
5	下塞 CROWN RACE	碳鋼 STEEL	841-6	1	Ø30 ^{+0.1}

H841SW



WEIGHT 161g
SIZE 1-1/8"x26T
DIMENSIONS Ø25.4x34x30

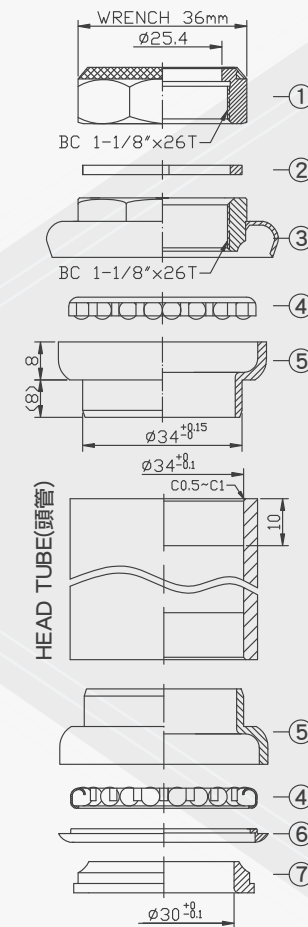

堆積高度(STACK HEIGHT)=37.5±1mm

NO.	零件名稱 PART NAME	材質 MATERIAL	圖號 DRAWING NO.	台量 Q' TY	尺寸 DIM. DESCRIPTION
1	防水上迫緊 LOCK NUT WITH SEAL	碳鋼 STEEL	841SW-1	1	BC 1-1/8"x26T
2	有領華司 KEY WASHER	塑膠 NYLON	SK3402	1	2txOD34(1-1/8")
3	上塞 ADJUSTING CONE	碳鋼 STEEL	841-3	1	BC 1-1/8"x26T
4	珠巢 BALL RETAINER	碳鋼 STEEL		2	5/32"x22
5	碗 CUPS	碳鋼 STEEL	841-4	2	Ø34 ^{+0.15}
6	防水圈 DUST-RESISTANT COVER	塑膠 NYLON	841SW-8	1	
7	下塞 CROWN RACE	碳鋼 STEEL	841-6	1	Ø30 ^{+0.1}

H841SW-P



WEIGHT 174g
SIZE 1-1/8"x26T
DIMENSIONS Ø25.4x34x30

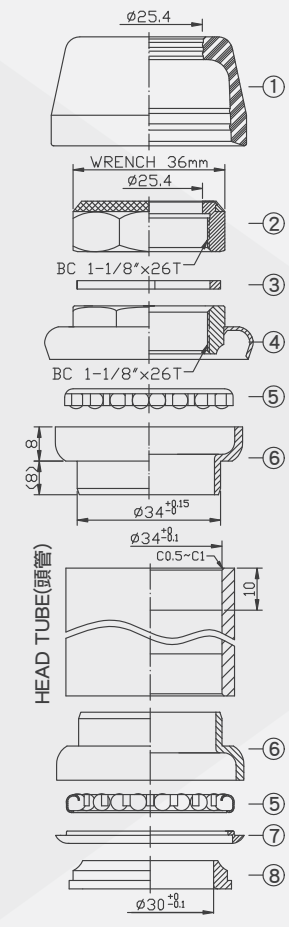

堆積高度(STACK HEIGHT)=37.5±1mm

NO.	零件名稱 PART NAME	材質 MATERIAL	圖號 DRAWING NO.	台量 Q' TY	尺寸 DIM. DESCRIPTION
1	塑膠蓋 TOP COVER	塑膠 NTLON	113-0	1	1-1/8"
2	防水上迫緊 LOCK NUT WITH SEAL	碳鋼 STEEL	841SW-1	1	BC 1-1/8"x26T
3	有領華司 KEY WASHER	碳鋼 STEEL	SK3402	1	2txOD34(1-1/8")
4	上塞 ADJUSTING CONE	碳鋼 STEEL	841-3	1	BC 1-1/8"x26T
5	珠巢 BALL RETAINER	碳鋼 STEEL		2	5/32"x22
6	碗 CUPS	碳鋼 STEEL	841-4	2	Ø34 ^{+0.15}
7	防水圈 DUST-RESISTANT COVER	塑膠 NYLON	841SW-8	1	
8	下塞 CROWN RACE	碳鋼 STEEL	841-6	1	Ø30 ^{+0.1}

H842-2



WEIGHT 190g
SIZE 1-1/8"x26T
DIMENSIONS Ø25.4x34x30

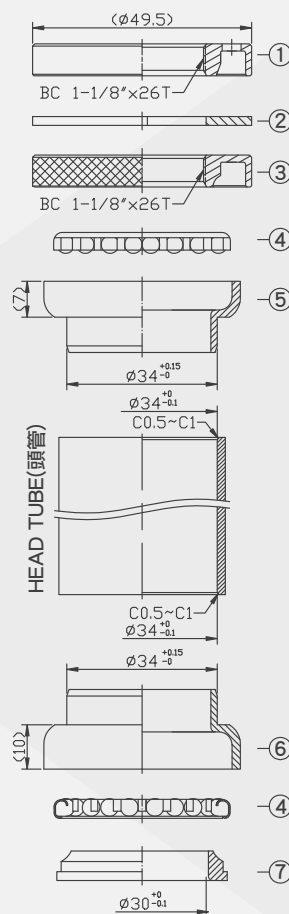

堆積高度(STACK HEIGHT)=30.5±1mm

NO.	零件名稱 PART NAME	材質 MATERIAL	圖號 DRAWING NO.	台量 Q' TY	尺寸 DIM. DESCRIPTION
1	上迫緊 LOCK NUT	碳鋼 STEEL	842-2-1	1	BC 1-1/8"x26T
2	大華司 KEY WASHER	碳鋼 STEEL		1	2txOD49.5(1-1/8")
3	上塞 ADJUSTING CONE	碳鋼 STEEL	842-2-3	1	BC 1-1/8"x26T
4	珠巢 BALL RETAINER	碳鋼 STEEL		2	5/32"x22
5	上碗 UPPER CUP	碳鋼 STEEL	703-45	2	Ø34 ^{+0.15}
6	下碗 LOWER CUP	碳鋼 STEEL	842-2-5	1	Ø34 ^{+0.15}
7	下塞 CROWN RACE	碳鋼 STEEL	841-6	1	Ø30 ^{+0.1}

H842SW



WEIGHT 149g
SIZE 1-1/8"x26T
DIMENSIONS Ø25.4x34x30

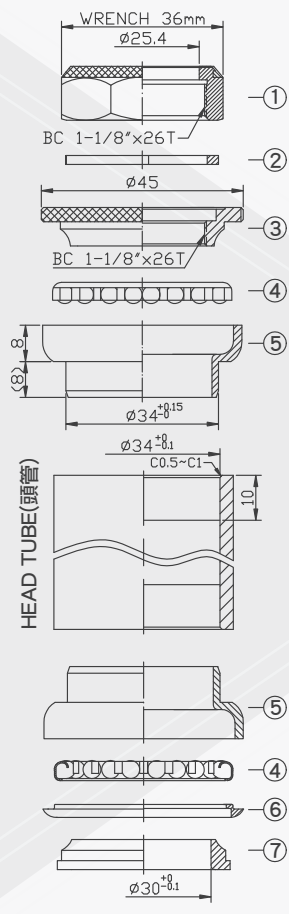

堆積高度(STACK HEIGHT)=34±1mm

NO.	零件名稱 PART NAME	材質 MATERIAL	圖號 DRAWING NO.	台量 Q' TY	尺寸 DIM. DESCRIPTION
1	防水上迫緊 LOCK NUT WITH SEAL	碳鋼 STEEL	841SW-1	1	BC 1-1/8"x26T
2	有領華司 KEY WASHER	碳鋼 STEEL	SK3402	1	2txOD34(1-1/8")
3	上塞 ADJUSTING CONE	碳鋼 STEEL	842-3	1	BC 1-1/8"x26T
4	珠巢 BALL RETAINER	碳鋼 STEEL		2	5/32"x22
5	碗 CUPS	碳鋼 STEEL	841-4	2	Ø34 ^{+0.15}
6	防水圈 DUST-RESISTANT COVER	塑膠 NTLN	841SW-8	1	
7	下塞 CROWN RACE	塑膠 NYLON	841-6	1	Ø30 ^{+0.1}

H843NW



WEIGHT 188g
SIZE 1-1/8"x26T
DIMENSIONS Ø25.4x34x30

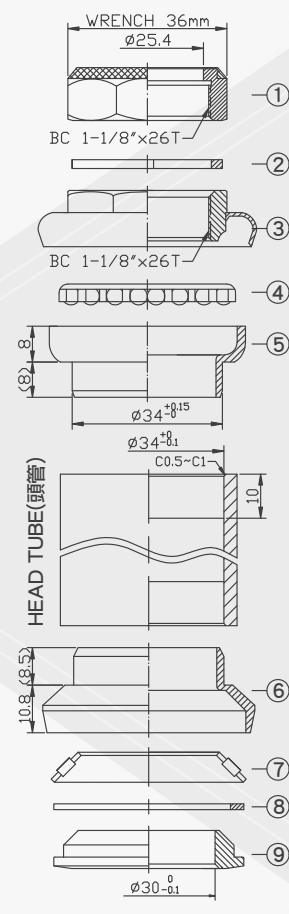

堆積高度(STACK HEIGHT)=39±1mm

NO.	零件名稱 PART NAME	材質 MATERIAL	圖號 DRAWING NO.	台量 Q' TY	尺寸 DIM. DESCRIPTION
1	防水上迫緊 LOCK NUT WITH SEAL	碳鋼 STEEL	841SW-1	1	BC 1-1/8"x26T
2	有領華司 KEY WASHER	碳鋼 STEEL	SK3402	1	2txOD34(1-1/8")
3	上塞 ADJUSTING CONE	碳鋼 STEEL	841-3	1	BC 1-1/8"x26T
4	珠巢 BALL RETAINER	碳鋼 STEEL		1	5/32"x22
5	上碗 UPPER CUP	碳鋼 STEEL	841-4	1	Ø34 ^{+0.15}
6	下碗 LOWER CUP	碳鋼 STEEL	856-5	1	Ø34 ^{+0.15}
7	條珠珠巢 NEEDLE BEARING	碳鋼 STEEL		1	Ø2.5x22
8	防水圈 RUBBER SEAL	橡膠 NBR	856-8	1	
9	條珠下塞 CROWN RACE	碳鋼 STEEL	856-6	1	Ø30 ^{+0.1}

